



PEOPLE'S DEMOCRATIC REPUBLIC OF ALGERIA
Ministry of Higher Education and Scientific Research
University of Amar Telidji - Laghouat



Faculty of Technology
Department of Electronics

MASTER THESIS

DOMAIN: Science & Technology

FIELD: Electronics

SPECIALTY: Instrumentation

LAGRAA Souhil Zine Elabidine & SABBA Mokhtar

Theme

Desing and Realization of PV Panel Curves Tracer

Jury members:

SEGHIER Tahar	Pr	President
OUBBATI Ibrahim Khalil	MCB	Examiner
ABOUCHABANA Nabil	MCB	Supervisor
HADJAISSA Aboubakeur	MCA	Co-Supervisor

2023 / 2024

Abstract

The project aims to design and implement an innovative photovoltaic curve tracer (PVCT), an advanced tool for accurately measuring the electrical characteristics of photovoltaic panels. This device contributes to improving the testing and maintenance processes of photovoltaic panels while enabling performance evaluation over time to ensure high efficiency and energy sustainability. The project began with an in-depth study of photovoltaic panel characteristics, including an analysis of current methods used for extracting electrical data. During the theoretical design phase, the focus was on developing a device that relies on an electronic load to achieve optimal performance. The practical implementation included several steps: - Selecting precise electronic components, such as voltage and current sensors, a TFT display, a temperature sensor, and MOSFET switches. - Conducting preliminary tests to verify the efficiency of the design. - Designing final printed circuit boards (PCBs). - Developing integrated software for device control and data analysis. The experimental results of the prototype demonstrated high efficiency and reliability, making it an effective tool for characterizing the performance of photovoltaic panels. To ensure the project's sustainability and market impact, a comprehensive business plan was developed, aiming to establish a startup to commercialize this innovation, thereby contributing to the promotion of renewable energy use and the development of local technology. **key words:** PV: Photovoltaic , PVCT: PV Curve Tracer , TFT display ,temperature sensor ,MOSFET,voltage sensor ,current sensor.

ملخص:

يهدف المشروع إلى تصميم وتنفيذ جهاز مبتكر لمتابعة منحنى الطاقة الكهروضوئية، وهو أداة متقدمة لقياس الخصائص الكهربية للألواح الكهروضوئية بدقة. يساهم هذا الجهاز في تحسين عمليات اختبار وصيانة الألواح الكهروضوئية، كما يتيح تقييم أدائها بمرور الوقت لضمان تحقيق كفاءة عالية واستدامة الطاقة.

بدأ المشروع بدراسة متعمقة لخصائص الألواح الكهروضوئية، شملت تحليل الأساليب الحالية المستخدمة لاستخراج البيانات الكهربية. تم التركيز خلال مرحلة التصميم النظري على تطوير جهاز يعتمد على الحمل الإلكتروني لتحقيق أداء مثالي.

تضمن التنفيذ العملي عدة خطوات شملت:

- ومستشعر TFT اختيار مكونات إلكترونية دقيقة مثل مستشعرات الجهد والتيار، وشاشة عرض من نوع (MOSFET) حرارة، ومفاتيح إلكترونية.
- إجراء اختبارات أولية للتحقق من كفاءة التصميم.
- النهائية (PCB) تصميم لوحات الدوائر المطبوعة.
- تطوير برمجيات متكاملة للتحكم في الجهاز وتحليل البيانات.

أظهرت النتائج التجريبية للنموذج الأولي كفاءة عالية وموثوقية كبيرة، مما يجعله أداة فعالة لتوصيف أداء الألواح الكهروضوئية.

لضمان استدامة المشروع وتحقيق أثره في السوق، تم وضع خطة عمل شاملة تهدف إلى إنشاء شركة ناشئة لتسويق هذا الابتكار، بما يساهم في تعزيز استخدام الطاقة المتجددة وتطوير التكنولوجيا المحلية.

Résumé

Le projet vise à concevoir et à mettre en œuvre un traceur de courbe photovoltaïque (PVCT) innovant, un outil avancé permettant de mesurer avec précision les caractéristiques électriques des panneaux photovoltaïques. Cet appareil contribue à améliorer les processus de test et de maintenance des panneaux photovoltaïques, tout en permettant une évaluation de leur performance au fil du temps pour garantir une efficacité élevée et une durabilité énergétique.

Le projet a débuté par une étude approfondie des caractéristiques des panneaux photovoltaïques, incluant une analyse des méthodes actuelles utilisées pour extraire les données électriques. Lors de la phase de conception théorique, l'accent a été mis sur le développement d'un appareil basé sur une charge électronique pour atteindre des performances optimales.

La mise en œuvre pratique a inclus plusieurs étapes : - La sélection de composants électroniques précis, tels que des capteurs de tension et de courant, un écran TFT, un capteur de température et des interrupteurs MOSFET. - La réalisation de tests préliminaires pour vérifier l'efficacité du design. - La conception des cartes de circuits imprimés (PCB) finales. - Le développement de logiciels intégrés pour le contrôle de l'appareil et l'analyse des données.

Les résultats expérimentaux du prototype ont démontré une grande efficacité et une fiabilité élevée, faisant de cet appareil un outil efficace pour caractériser les performances des panneaux photovoltaïques.

Pour garantir la durabilité du projet et son impact sur le marché, un plan d'affaires complet a été élaboré, visant à créer une startup pour commercialiser cette innovation, contribuant ainsi à promouvoir l'utilisation des énergies renouvelables et à développer la technologie locale.

Acknowledgements

We would like to express our heartfelt appreciation to our advisor, Prof., Dr.ABOUCHABANA Nabil, and our co-supervisor, Dr.HADJ AISSA ABoubakeur, for their invaluable guidance, patience, and encouragement throughout our journey as their students. Their unwavering support and prompt responsiveness to our questions have been instrumental in our progress.

We would also like to thank the committee members,Dr.OUBBATI Ibrahim khalil, Dr.AMEUR khaled and Dr. RAHMANI Youcef Zakaria for serving us as our committee members. We would especially like to thank everyone helps us to get this work accomplished. We would also like to thank our families. Words cannot express how grateful

we are to our parents for all of the sacrifices that they have made. Their prayers and support for us were what sustained us thus far. We would also like to thank all of our friends who supported us in preparing this project, and incented us to strive towards our goal. Finally, I would like to thank the teaching team and administrative body of the Faculty of technology for the richness and quality of their teaching, and they go to great lengths to provide their students with up-to-date training.

LAGRAA Souhil Zine Elabidine & SABBA Mokhtar
Laghouat University
December 2024

Contents

Abstract	i
Acknowledgements	iv
List of Figures	ix
Abbreviation	x
General Introduction	xi
1 Photovoltaic Panel	1
1.1 Introduction	1
1.2 Photovoltaic Panel	1
1.3 Equivalent Circuit and Mathematical Model of a PV Cell	1
1.4 Electrical Characteristics of a Photovoltaic Panel	2
1.4.1 Current-Voltage Characteristic	3
1.4.2 Power-Voltage Characteristic	3
1.5 Overview of PV Tracers	3
1.5.1 Variable resistive load method	4
1.5.2 Capacitive load method	5
1.5.3 Electronic load method	6
1.5.4 Four-quadrant power supply method	7
1.5.5 DC-DC converter method	8
1.6 Conclusion	9
2 Study and Design of The PV Tracer	10
2.1 Introduction	10
2.2 Overview of the Various Components of The PV Tracer	10
2.3 The Electronic Load	11
2.3.1 Definition	11
2.3.2 Power Stage	11
2.3.3 Control Stage	11
2.3.4 Operating Principle of the Implemented Electronic Load	12
2.3.5 Advantages of Using MOSFETs	12
2.3.6 How the Electronic Load Works	13
2.4 Measurement of PV characteristic ,Temperature and solar radiation	15
2.5 Micro-controller	15

2.5.1	Definition	15
2.5.2	The Role of the Micro-controller	15
2.6	Display screen	15
2.7	power supply	16
2.7.1	Input Power (220V AC)	16
2.7.2	Protection Circuit	16
2.7.3	Power Supply for Control Stage:	16
2.7.4	Power Supply for Sensors and ESP32	16
2.8	conclusion	16
3	Realization of PV Tracer	18
3.1	Introduction	18
3.2	Power Supply Board	18
3.2.1	Protection Circuit and Transformer	18
3.2.2	Rectifier and Filter	18
3.2.3	Voltage Regulation	19
3.2.4	Power Stage and Voltage/Current Measurement Board	19
3.2.5	Power Stage	20
3.2.6	Voltage/Current Measurement	22
3.3	Control Board	23
3.3.1	Micro-controller	24
3.3.2	Control Stage	25
3.3.3	Measurement of Temperature	26
3.3.4	Analog-to-Digital Converter (ADC)	26
3.4	The Display Screen and Software Interface	26
3.4.1	Display Screen TFT-Dispaly	26
3.4.2	Software Interface	27
3.5	Tests of a PV Curve Tracer	28
3.6	Prototype Overview	31
3.6.1	Photovoltaic System Interface	31
3.6.2	Challenges Faced	32
3.6.3	Future Improvements	33
3.7	Conclusion	33
4	Economic Study of PV Tracer	34
4.1	Introduction	34
4.2	Start-Up	35
4.3	Project Introduction	35
4.3.1	Project Idea(Proposed Solution)	35
4.3.2	Suggested Values:	35
4.3.3	Work Team	35
4.3.4	Project Objectives	36
4.3.5	Project Implementation Timeline	36
4.4	Innovative Aspects	36
4.4.1	Nature of Innovations	36
4.4.2	Areas of Innovation	37
4.5	The Strategic Market Analysis	37
4.5.1	Market Segment View	37
4.5.2	Measuring The Intensity of Competition	37
4.5.3	Marketing Strategy	38

4.5.4	Environmental Analysis SWOT	39
4.5.5	Exit Strategy	40
4.6	Production and Organization	40
4.6.1	Production process	40
4.6.2	Supply	41
4.6.3	Labor Force	41
4.6.4	Key partnerships	41
4.7	Financial Plan	42
4.7.1	Costs and Burdens	42
4.7.2	Business Number	42
4.7.3	. Expected Results Calculation Table	42
General Conclusion		44

List of Figures

1.1	Structure of a photovoltaic cell using silicon as a PV material.	2
1.2	Equivalent circuit of a photovoltaic cell.	2
1.3	Power-voltage and current-voltage characteristics of a photovoltaic cell. . . .	3
1.4	Block diagram of I–V curve tracking in a PV system.	4
1.5	Variable resistor method circuit topology proposed	5
1.6	Capacitive load method scheme for I–V curve tracer.	6
1.7	Basic schematic circuit for I–V curve tracer using MOSFET as electronic load.	7
1.8	A comparison of the I–V characteristics of MOSFET and the PV module output.	7
1.9	An I–V curve taken with a four-quadrant power supply	8
1.10	Basic schematic circuit for I–V curve tracing using four-quadrant power supply method	9
1.11	Commonly used DC–DC converters in PV side power interface: (a) Buck-boost converter. (b) Cuk converter. (c) Zeta converter. (d) SEPIC	9
2.1	:Schematic Diagram of the Characterization PV panle	11
2.2	:Operating Point Variation Based on Load	12
2.3	:Schematic Diagram of the Electronic Load	12
2.4	:Operating Principle of the Implemented Electronic Load.	14
2.5	:Characteristic $I_d = f(V_{GS})$ IRFP150	14
3.1	:Schematic Diagram of the Power supply	19
3.2	:The (PCB) of the power supply.	20
3.3	:Schematic Diagram of the Power Stage and Voltage/Current Measurement	21
3.4	:The (PCB) of the Power board	22
3.5	:LA25-NP current sensor	23
3.6	:LV25-P voltage sensor	23
3.7	:Schematic Diagram of the Control board	24
3.8	:The (PCB) of the Control Board.	24
3.9	:ESP32 Wroom Card	25
3.10	:Schematic Diagram of the Control Stage	26
3.11	: The ADS1115 Analog to Digital Converter	27
3.12	: TFT Dispaly (ST77960)	27
3.13	: Diagram of the software system	28
3.14	: The Front Panel of PV Tracer	29
3.15	: External appearance of PV Tracer.	31
3.16	: External appearance of PV Tracer.	32

3.17 : the initial prototype of our project. 32

Abbreviation

Abbreviation	Definition
PV	photovoltaic
Voc	Open-Circuit Voltage
C	Capacitor
Vp	PV voltage
E	Solar irradiance
Vgs	gate-source voltage
Icell	CURRENT CELL
Isc	Short Circuit Current
Id	Current diode
Ip	PV current
Id	drain current
Vd	drain voltage
MPP	maximum power point
Impp	current at Maximum Power
T	temperature
Pmax	Maximum Power
Kn	constant
PV	Photovoltaic
R	resistance
Vmpp	Voltage at Maximum Power
Voc	Open Circuit Voltage

General Introduction

In recent years, humankind has turned to renewable energy in a big way because of its contribution to preserving the environment, and there are many sources of renewable energy such as wind energy, hydroelectric power, the earth's internal heat and solar energy in all its forms. Solar energy is one of the most important and abundant renewable energy sources in many countries and is harnessed through light rays and the resulting thermal energy and used to generate electrical energy and produce a number of chemical reactions and used as an alternative to fuel and others. One of the techniques used for energy conversion is the use of photovoltaic arrays, which convert light rays into electrical energy through a photovoltaic cell made of semiconductors with photovoltaic effect, and researchers are working to study and develop these technologies to increase their productivity.

Photovoltaic energy has its pros, including minimizing CO₂ emissions and contributing to the reduction of global warming, and does not require complex infrastructure.

It also has disadvantages, of course, including the high cost of producing energy only during the day, which makes it need a power supply at night and is affected by weather fluctuations.

Generally, the association of non-identical photovoltaic (PV) panels, whether connected in series or in parallel, affects the overall efficiency of the PV generator, as the weakest panel limits the power output of the entire system. In this context, it is essential to know the exact power output of each panel before integrating it into the PV generator to optimize efficiency and avoid performance losses due to mismatches between panels. For this reason a PV curves tracer is needed.

The purpose of this work is to design and realize a PV Panel curves tracer based on ESP 32 micro controller. This Tracer, accompanied by a TFT display, is designed to trace the current-voltage (I-V) and power-voltage (P-V) characteristics of a photovoltaic (solar) panel for determined temperatures and solar radiation. This allows for an accurate characterization of PV panels. Knowing these characteristics is essential for studying photovoltaic generators as well as for the sizing and optimization of the installations. The written thesis pertaining to this work is organized into four chapters

- **The first chapter:** This chapter includes the definition of a photovoltaic generator and its structure, knowledge of photovoltaic characteristics, and explanation of some of the methods used to characterize generators.
- **The second chapter** The concept of the photoelectric characteristic curve plotter is explained in detail.
- **the third chapter** In this final chapter, we will present the method and the final results of the project.

- **Chapter Four** This chapter focuses on the economic study of device production.
- **Finally** we present a general summary of our study in this memorandum

Chapter 1

Photovoltaic Panel

1.1 Introduction

Photovoltaic solar energy is generated using photovoltaic panels. In this chapter, we define these panels, explore their characteristics, and examine the methods used to determine these characteristics.

1.2 Photovoltaic Panel

In 1839, the physicist Alexander E. Becquerel discovered the photoelectric effect, which refers to the conversion of light energy into electrical energy.

The photovoltaic cell is the fundamental component of photovoltaic solar panels. It is a silicon-based semiconductor device that delivers a voltage of approximately 0.5 to 0.6 V. A photovoltaic cell functions as a sensor made of semiconductor material that absorbs light energy and directly converts it into electrical current. The operating principle of this cell relies on the ability of semiconductor materials to absorb light radiation. The choice of materials used to design PV cells is based on their physical properties, specifically the ability of some electrons to be released from their atoms when excited by photons from the solar spectrum. The energy required for this process depends on the wavelength of the incident light. Once freed, these charges move through the material, generating an overall direct current (DC). This movement of charge carriers results in an electromotive force (emf) at the terminals of the semiconductor, corresponding to the physical phenomenon known as the photovoltaic effect.

1.3 Equivalent Circuit and Mathematical Model of a PV Cell

A PV cell (Figure 1.2) can be modeled using a current generator to represent the incident light flux, a diode to account for cell polarization phenomena, and two resistances (series and shunt) to model losses. The resistances R_s and R_{sh} account for losses related to manufacturing defects. Specifically, R_s represents contact and connection resistances, while R_{sh} characterizes leakage losses.

Mathematical Model: The leakage currents due to the diode and edge effects of the junction are expressed as:

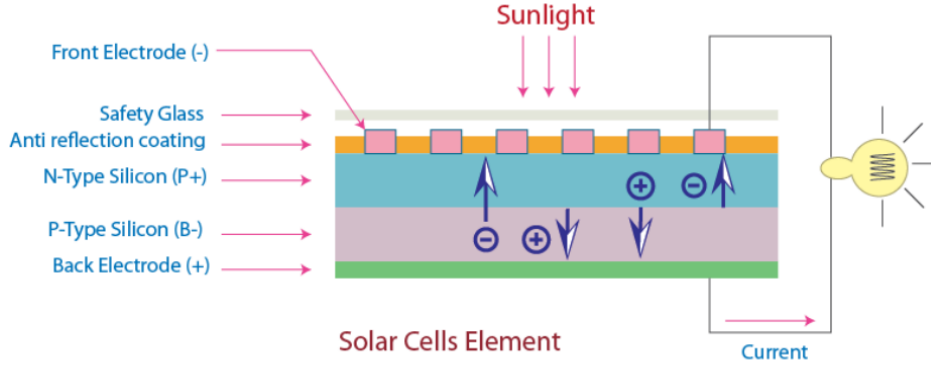

Figure 1.1: Structure of a photovoltaic cell using silicon as a PV material.

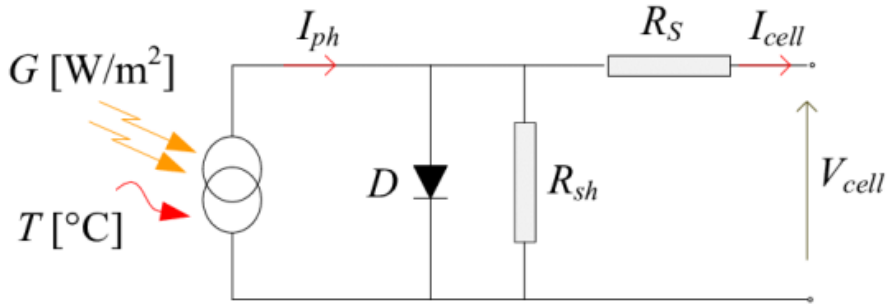

Figure 1.2: Equivalent circuit of a photovoltaic cell.

$$I_{ph} = I_D + I_{sh} + I_{cell} \quad (1.1)$$

The junction current is given by:

$$I_D = I_{sat} \left[e^{\frac{q(V_{cell} + I_s R_s)}{nkT_e}} - 1 \right] \quad (1.2)$$

The current in the shunt resistor is given by:

$$I_{sh} = \frac{V_{cell} + I_s \cdot R_s}{R_{sh}} \quad (1.3)$$

From equation (1.1), we obtain the expression for the I-V characteristic of the cell:

$$I_{cell} = I_{ph} - I_{sat} \left[e^{\left(\frac{q(V_{cell} + I_s \cdot R_s)}{n \cdot k \cdot T_e} \right)} - 1 \right] - \frac{V_{cell} + I_s \cdot R_s}{R_{sh}} \quad (1.4)$$

1.4 Electrical Characteristics of a Photovoltaic Panel

The characteristics of photovoltaic panels enable the classification of solar panels based on their maximum power point, ensuring that installations are optimized for high efficiency.

1.4.1 Current-Voltage Characteristic

The current-voltage characteristic, illustrated in Figure (1.3), describes the behavior of a photovoltaic cell under varying weather conditions (light intensity and temperature). The I-V curve passes through three critical points:

Open-Circuit Voltage (V_{oc}): The maximum voltage of the solar cell when no current is flowing.

Short-Circuit Current (I_{sc}): The maximum current of the solar cell when the terminals are shorted.

Maximum Power Point (MPP): The point where the product of current and voltage is maximized, representing the optimal operating condition.

1.4.2 Power-Voltage Characteristic

This characteristic, also illustrated in Figure (1.3), describes the power output behavior of the solar cell under specific conditions. The power-voltage characteristic passes through the **maximum power point (MPP)**, where the product of voltage and current reaches its peak.

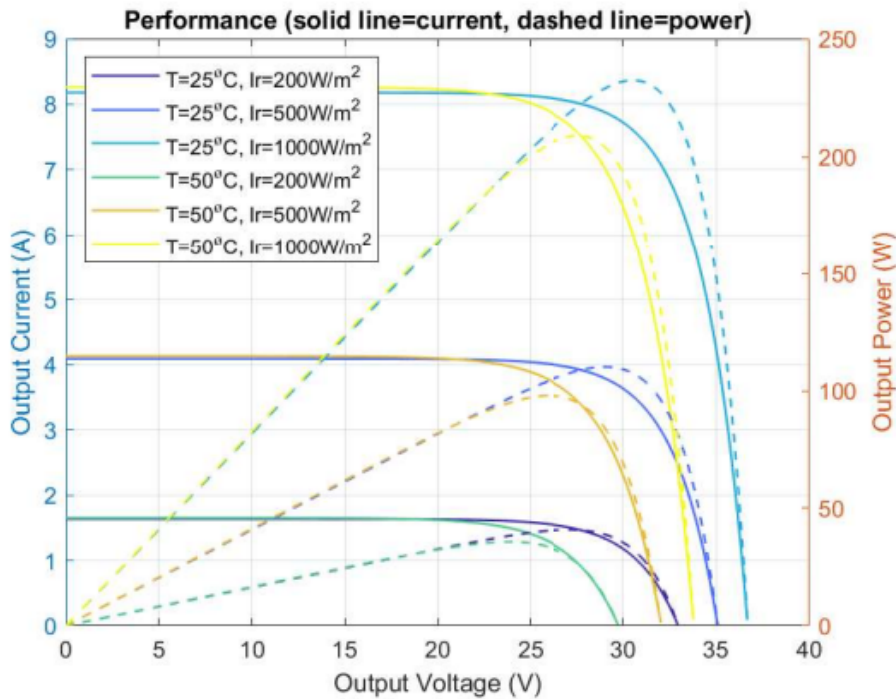

Figure 1.3: Power-voltage and current-voltage characteristics of a photovoltaic cell.

1.5 Overview of PV Tracers

I-V tracers function by converting a PV module from an open-circuit state to a short-circuit state while capturing the resulting changes in voltage and current. The system consists of three main components: a data acquisition (DAQ) system, a power conditioner, and a control strategy.

The DAQ system records voltage and current values from the PV module's terminals. A power conditioner, incorporating variable resistors or electronic loads, adjusts the load profile to obtain the complete I-V curve. The control strategy regulates power conditioning and data acquisition, ensuring accurate measurement of I-V characteristics.

A typical I-V tracing process is illustrated in Figure (1.4).

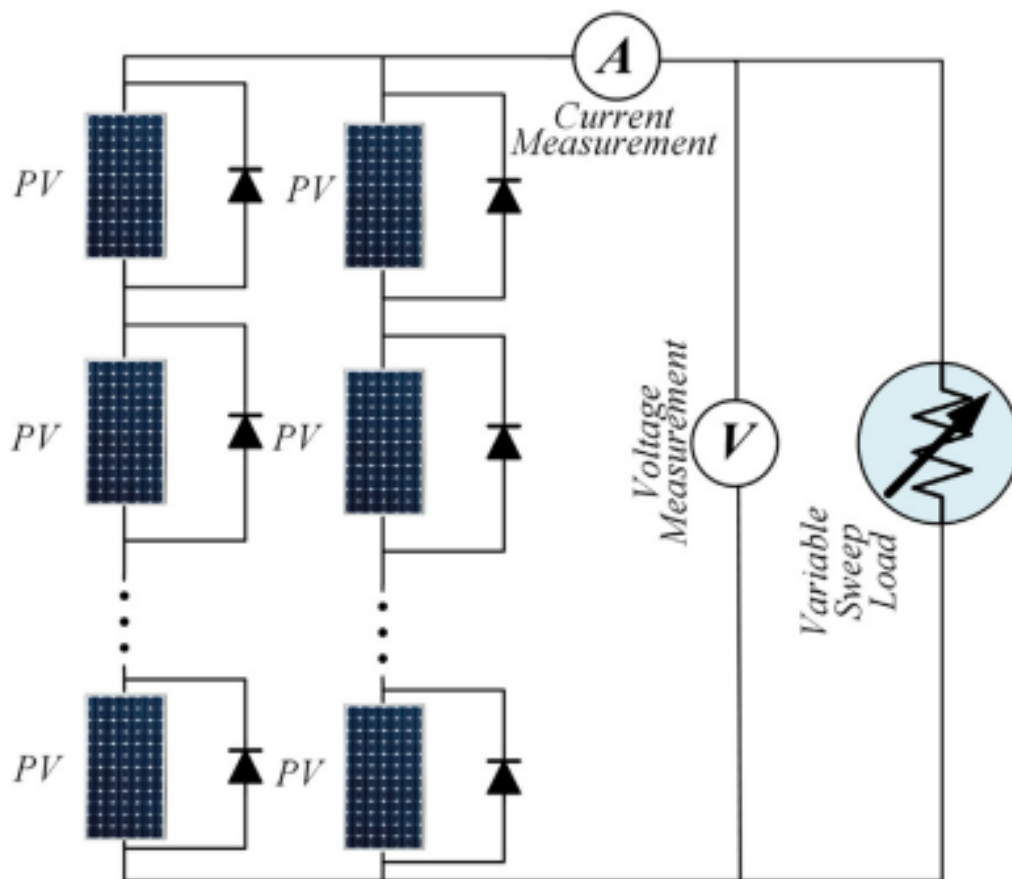

Figure 1.4: Block diagram of I-V curve tracking in a PV system.

.PV :Photovoltaic Panel

1.5.1 Variable resistive load method

The simplest method to measure the voltage-voltage curve is to connect a variable resistor to the outer terminal of the photovoltaic module. By varying the resistance from zero (short circuit) to infinity (open circuit), the points on the voltage-voltage curve can be captured. To improve measurement quality, a tracking algorithm is used to speed up the voltage-voltage tracker. The combination of resistors and switches helps achieve smooth voltage-voltage curves.

The circuit configuration is illustrated in Figure (1.5). It consists of a set of dual resistors that are alternately connected and disconnected to measure voltage and current from short circuit to open circuit. The switches are controlled by a microcontroller, which adjusts the resistor combination to reach the maximum resistance value R_{max} , expressed as follows:

$$R_{\max} = \sum_{k=0}^{n-1} 2^k R_0 \quad (1.5)$$

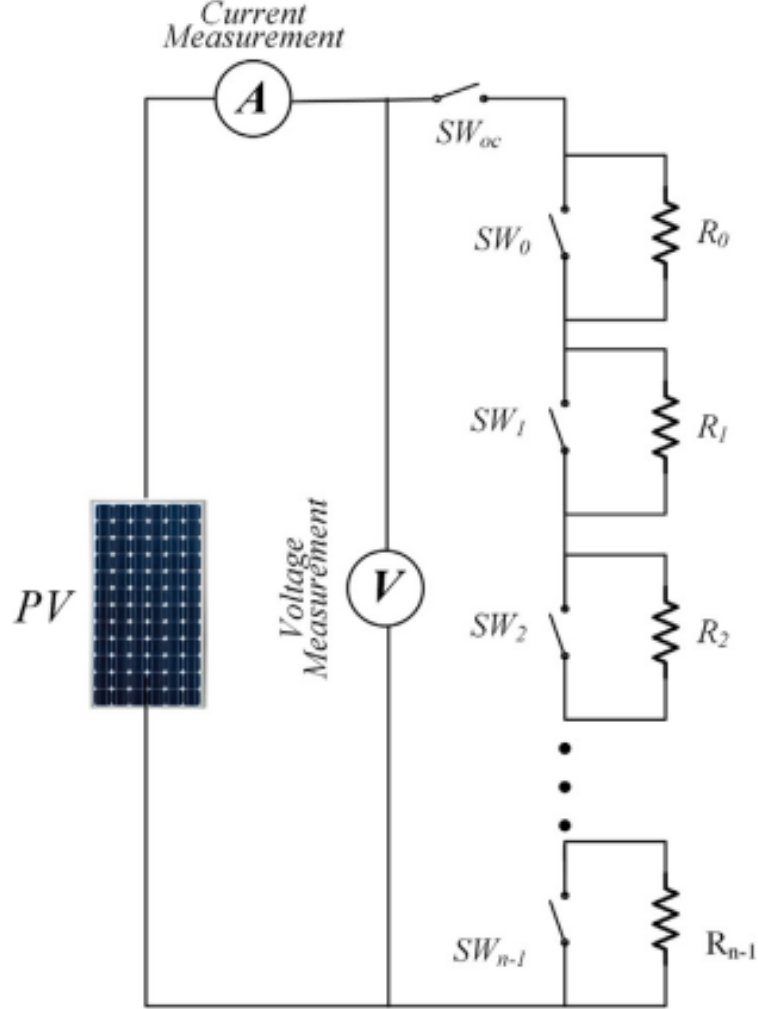

Figure 1.5: Variable resistor method circuit topology proposed

R :resistors. SW :switches. PV :Photovoltaic Panel

R_0 is the smallest resistance and defines the resolution of the I-V curve tracker. The advantage of this method is that it can quickly produce a smooth curve (in 540.2 ms) using only eight resistors. However, the resolution is limited to the smallest and largest resistance values, which may result in missing measurement points close to the open circuit voltage. [1]

1.5.2 Capacitive load method

The capacitive load method employs capacitors for voltage tracking applications. As the capacitor charges, the current decreases while the voltage increases, causing the voltage curve to shift negatively. The measurement circuit commonly used for this method is illustrated in Figure (1.6). The fundamental circuit and device prototype are described in Aguilar et al. (2017) and Recart et al. (2006a). Voltage and current are measured directly from the PV

module terminal, and a resistor connected to a switch is used to discharge the power after testing. [2] V_{pv} :PV output voltage i_{pv} :PV output current

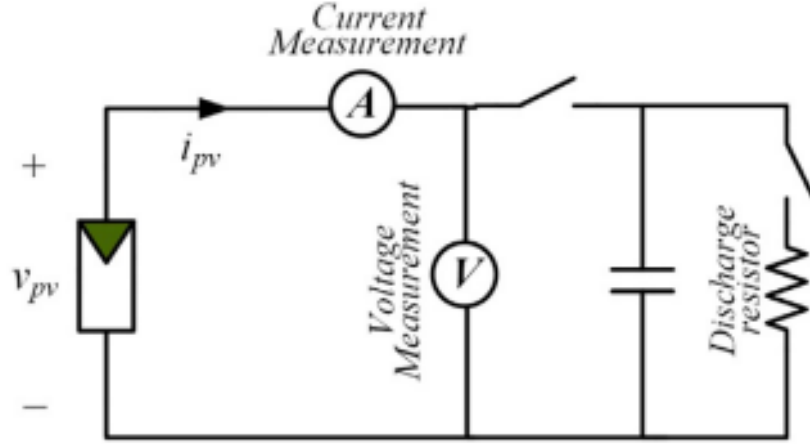

Figure 1.6: Capacitive load method scheme for I-V curve tracer.

1.5.3 Electronic load method

The electronic load method utilizes a transistor as the load, typically employing metal oxide semiconductor field-effect transistors (MOSFETs), bipolar junction transistors (BJTs), or insulated-gate bipolar transistors (IGBTs). In this method, the voltage between the drain and the source is modulated via the gate-source voltage (for MOSFETs and IGBTs) or current (for BJTs). This configuration allows for rapid scanning of the IV characteristics of PV modules.

MOSFETs, which are the most common type of electronic load, adjust the gate-source voltage (V_{GS}) to control the drain current (I_D). The basic circuit used for this method is depicted in Figure (1.7), where I_{PV} and V_{PV} represent the output current and voltage of the PV module, and V_{DS} represents the drain-source voltage. [3]

i_D :Drain current V_{DS} :Drain-Source Voltage V_{GS} :gate-source voltage

In conjunction with the I-V curves of the MOSFET and PV module, the matching point is illustrated when the gate signal, V_{GS} , is varied accordingly Figure (1.8). The drain current I_D and the PV output current I_{PV} are identical, making the measuring points the equality points in Figure (1.9).

The characteristics of a MOSFET are as follows: For the triode region:

$$I_D = K_N(2(V_{GS} - V_{th})V_{DS} - V_{GS}^2) \quad (1.6)$$

For the saturation region:

$$I_D = K_N(2(V_{GS} - V_{th})^2) \quad (1.7)$$

where K_N is the device constant, and V_{th} is the threshold voltage. The measuring points are the intersections of the I-V curve of the PV module with the I_D - V_{DS} curves of the MOSFET. The equation. for the intersection points can be written as:

$$I_D = I_{pv} \quad (1.8)$$

By adjusting V_{GS} within an appropriate range, the measuring points can sweep between I_{SC} (short-circuit current) and V_{OC} (open-circuit voltage). The innovation of this method lies in

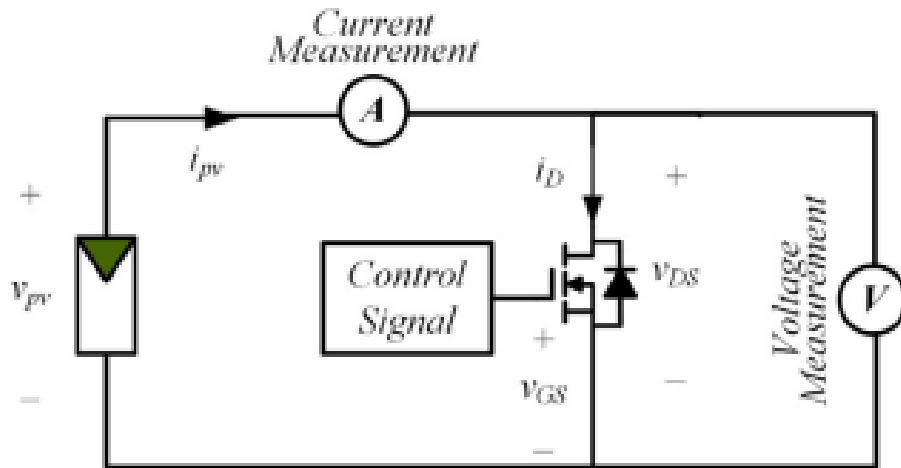

Figure 1.7: Basic schematic circuit for I-V curve tracer using MOSFET as electronic load.

its use of a current ramp instead of a voltage ramp for measurements. For the PV module, the MOSFET method provides linearly changing measurement points in the voltage source region, where i_D changes approximately linearly with V_{GS} . However, in the power region and current-source region, the I-V curve is nearly flat, making V_{PV} highly sensitive to small variations in V_{GS} . As a result, the measuring points move quickly in these regions. This limitation can be mitigated by introducing control circuits, such as a DC-DC converter.

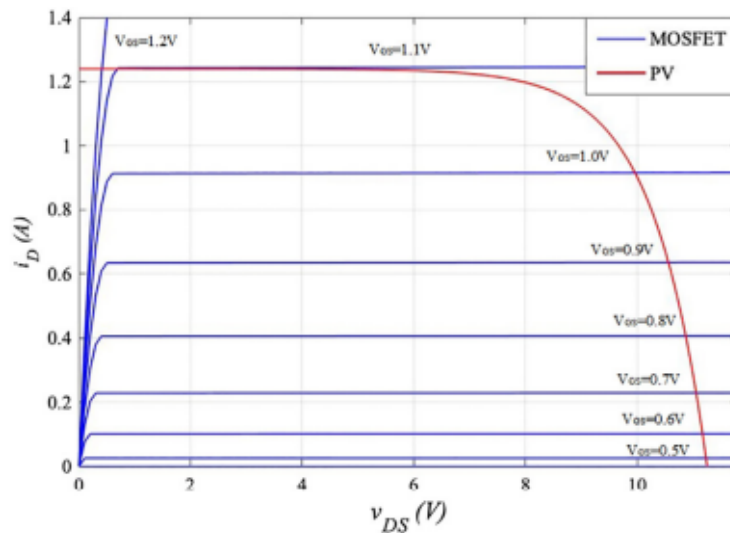

Figure 1.8: A comparison of the I-V characteristics of MOSFET and the PV module output.

1.5.4 Four-quadrant power supply method

Some researchers use a quadrant power supply to test the characteristics of AC. A quadrant power supply is a device that can both supply and dissipate power, commonly used to simulate DC power supplies, loads, PV arrays, and batteries. It operates in four quadrants Figure(1.9)

, with PV modules typically used in the first quadrant. However, points around the axes are important diagnostic indicators of mismatch effects.

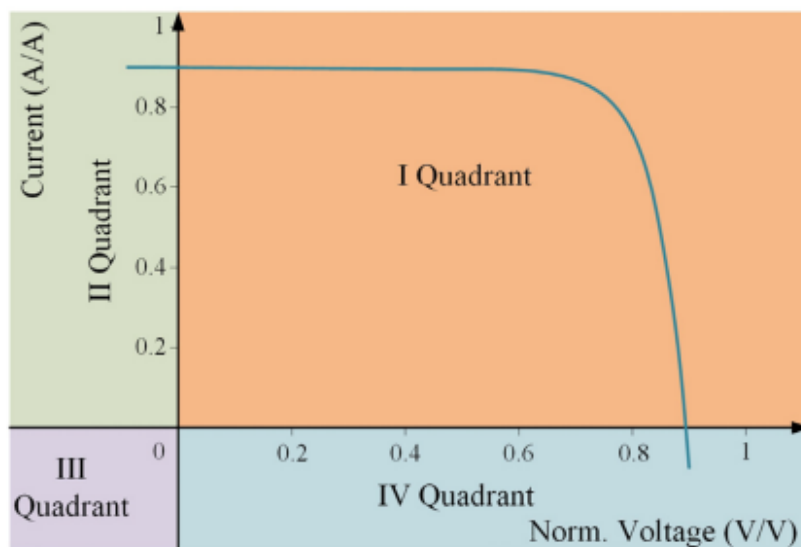

Figure 1.9: An I–V curve taken with a four-quadrant power supply .

The topology of this method is simple: the PV module is directly connected to a quadrant power supply controlled by a computer, as shown in Figure (1.10). During the scanning procedure, voltage and current values are read and stored.

In previously proposed systems, various voltage control methods have been developed. The voltage scan can be controlled manually or by generating a phase voltage ramp to perform a new measurement using two voltage ramps to capture more points in the knee portion of the I-V curve. This procedure has improved the accuracy of measuring the maximum power point (MPP) and the open-circuit point.

The quadrant power supply method is the fastest and most accurate of the four methods. A control strategy can be easily implemented through direct computer programming, with measurement ratings reaching 1000V/100A. However, quadrant power supplies are expensive and bulky, limiting their use to laboratory experiments. [4]

1.5.5 DC–DC converter method

The voltage transformation ratio of DC–DC converters can be utilized to change the virtual resistance at the input terminal, thereby acting as an I–V tracer. Figure (1.11) illustrates commonly used DC–DC converter topologies, including buck-boost, Cuk, Zeta, and single-ended primary inductor converter (SEPIC). These converters and loads can be programmed to simulate a resistive load, a controllable current load, or a flexibly controllable voltage load. The DAQ system works in conjunction with the programmable DC load to provide more accurate measurements.

Additionally, the DC–DC converter method is highly efficient and low-cost. However, one drawback of this method is that the power switching induces ripple in the voltage and current. [5]

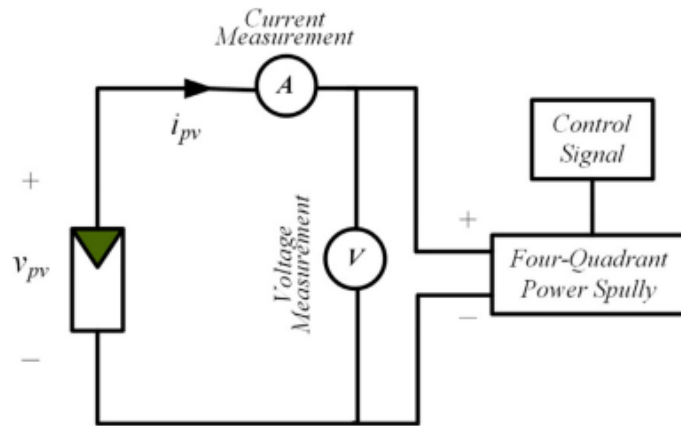

Figure 1.10: Basic schematic circuit for I–V curve tracing using four-quadrant power supply method .

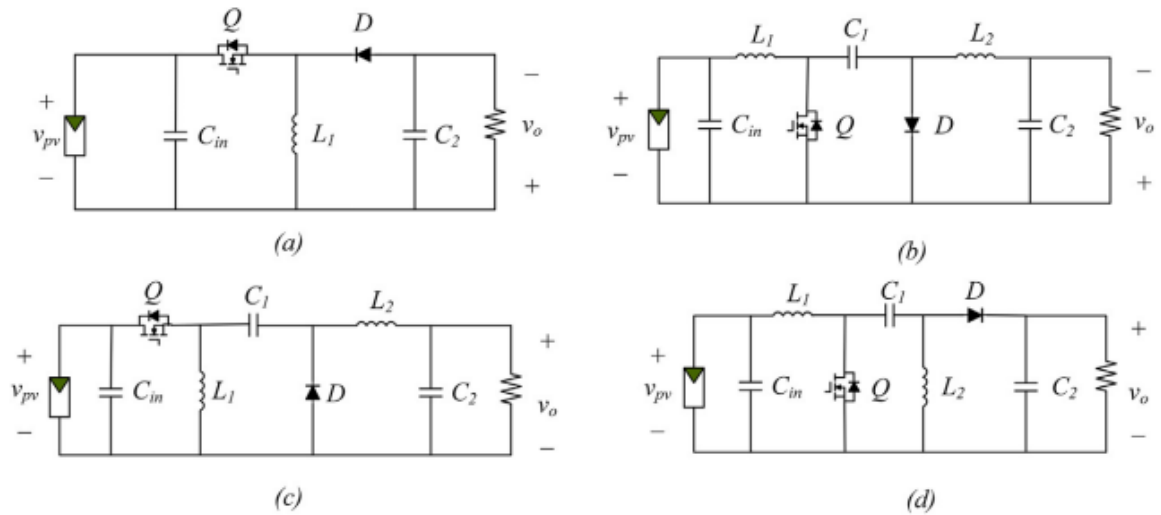

Figure 1.11: Commonly used DC–DC converters in PV side power interface: (a) Buck-boost converter. (b) Cuk converter. (c) Zeta converter. (d) SEPIC .

1.6 Conclusion

This chapter highlighted the importance of I–V and power-voltage characteristics for optimizing PV panels. Various methods, including resistive loads, capacitive loads, electronic loads, quadrant power supplies, and DC–DC converters, were explored for tracing these curves. Each method presents unique advantages, contributing to accurate PV performance analysis and system optimization.

Chapter 2

Study and Design of The PV Tracer

2.1 Introduction

The PV Tracer characterization is designed to map the I-V and P-V curves of solar panels under different temperatures and Radiation conditions. The use of MOSFETs in the electronic load allows scanning of the current from I_{sc} to 0 A to give precise control and efficient handling of the currents. This tool enables detailed performance monitoring and optimization of solar panels

2.2 Overview of the Various Components of The PV Tracer

The developed PV Tracer is designed to characterize photovoltaic panels by mapping the I-V and P-V curves under value of temperature and solar radiation conditions. To accomplish this, it measures the operating point I_{pv} V_{pv} and gather real-time data on temperature and solar radiation at the moment of measurement.

Consequently, the PV Tracer contain several blocks, as depicted in the accompanying figure2.1 illustrates an integrated characterization PV tracer designed to control the performance of a solar panel system. It begins with a 220V AC power input, which is protected and converted into the necessary DC voltages to power the system.

The main component is the ESP Wroom 32 micro-controller, which is connected to sensors that measure important parameters like current, voltage , radiation , and temperature. These sensors collect key data about the solar panel's output and environment.

An ADS1115 converter changes the analog signals from the sensors into digital data so the micro-controller can process them. The results are shown on a screen (TFT-Display), allowing the user to see real-time information.

The PV tracer includes a control stage linked to a power stage. This part manages the charging and discharging processes, helping the solar panel work efficiently and reliably.

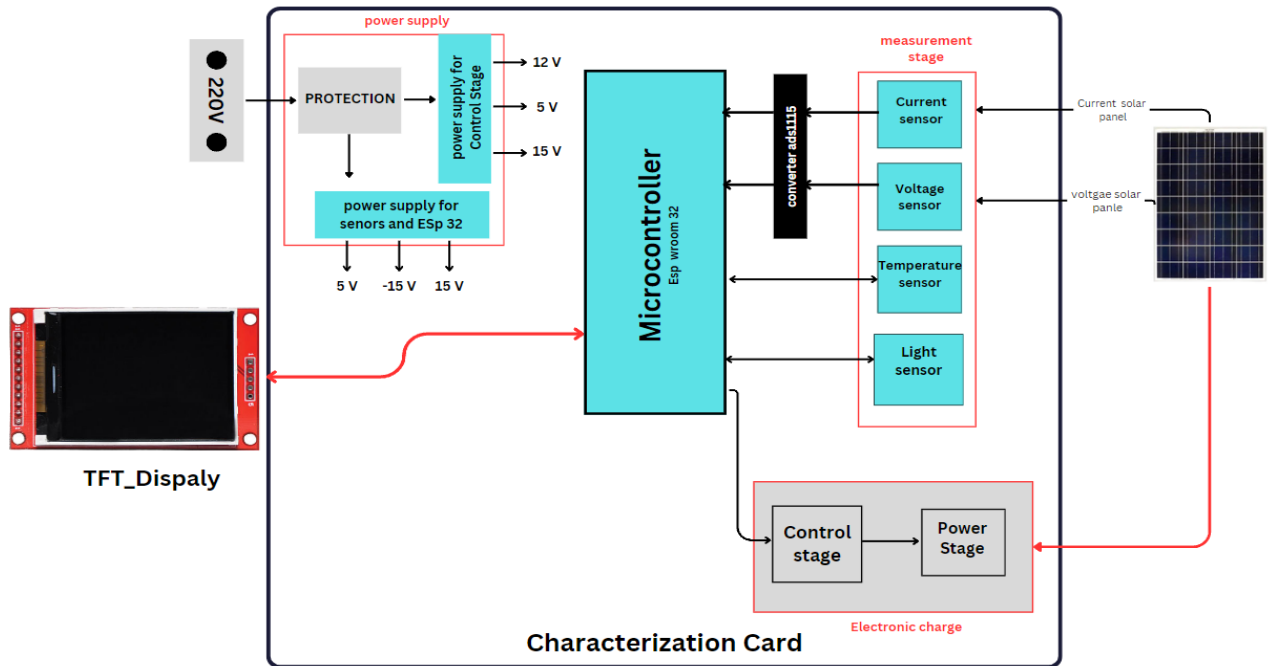

Figure 2.1: Schematic Diagram of the Characterization PV panel .

2.3 The Electronic Load

2.3.1 Definition

An electronic load is a device that simulates a static or dynamic load. Commonly used for testing power sources, it replaces traditional resistive loads (ohmic loads). Unlike conventional loads, the electronic load allows precise electronic control of the load current (or sometimes the voltage), offering the ability to regulate it within a specific range. The electronic load is a critical component in our design, and special attention will be given to its implementation. It consists of two stages.

2.3.2 Power Stage

This stage is directly connected to the photovoltaic panel, serving as a controllable impedance that allows us to vary the panel's operating point. This variation enables the collection of two key parameters: the panel current I_P and panel voltage V_P as figure 2.2 shows .

2.3.3 Control Stage

This stage is placed between the power stage and the micro-controller (μC). Its role is to control the power stage, specifically its impedance. In our case, it does not directly regulate the impedance of the power stage (as there is no feedback loop), but rather adjusts the current from 0 to the short-circuit current (I_{sc}), as shown in the figure 2.2. The two curves represent either two characteristics of the same panel under different temperature and light conditions or two I-V characteristics of two different panels. As shown in Figure 2.2, the shift in the operating point from QCC point to QCO point, shown in figure 2.2 allows the scanning of the I_V characteristic of the PV panel. A more detailed explanation of the electronic load, along with its electric circuit,

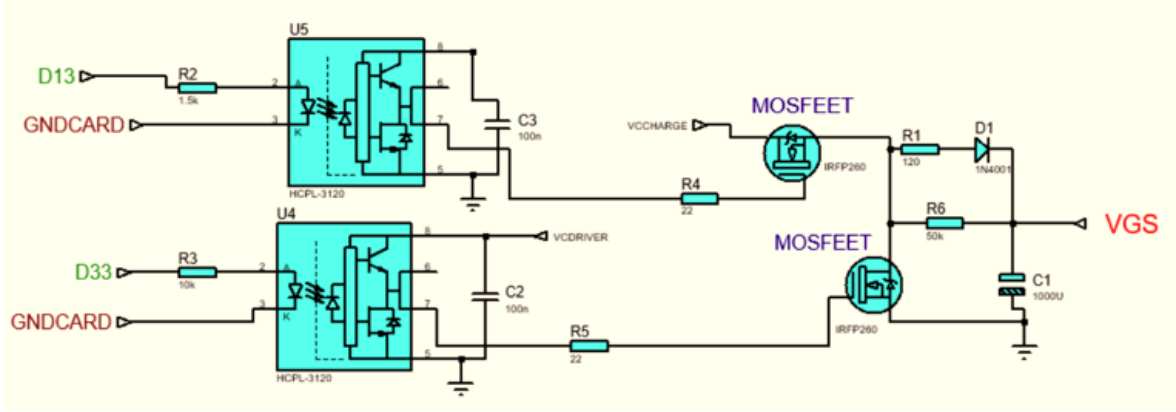

Figure 2.2: :Operating Point Variation Based on Load .

2.3.4 Operating Principle of the Implemented Electronic Load

the electronic load , it consists of two stages. Power Stage and Control Stage Figure 2.3 illustrates and explains the principle of operating. as figure 2.3 shows a MOSFET transistor

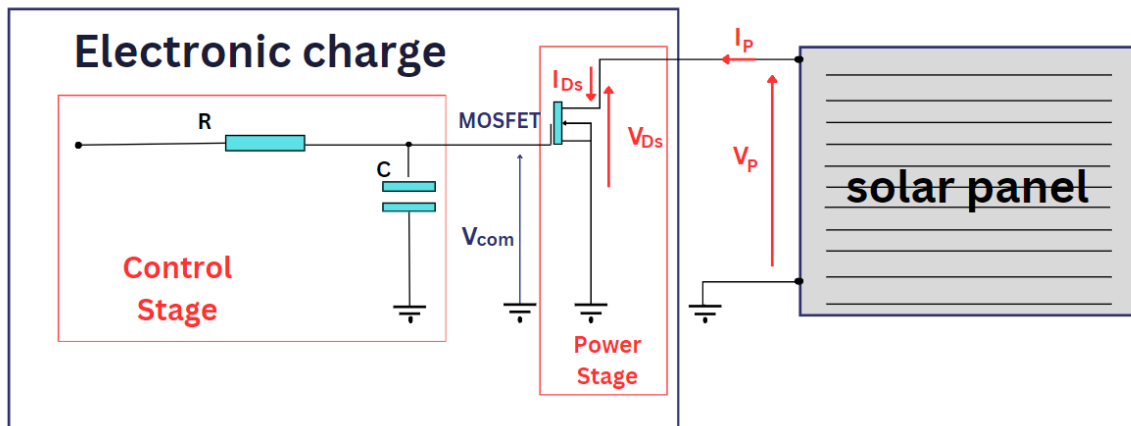

Figure 2.3: :Schematic Diagram of the Electronic Load .

used where the drains of the MOSFET are directly connected to the (+) terminal and (-) terminal of the PV panel

We notice that:

$$\begin{cases} I_P = I_{DS} \\ V_P = V_{DS} \end{cases}$$

2.3.5 Advantages of Using MOSFETs

Unlike bipolar power transistors, MOSFETs are easier to control and offer several advantages, including the following:

- They support high currents, often reaching several tens of amperes
- They are not prone to the second breakdown phenomenon or thermal runaway, unlike bipolar transistors. In fact, the drain-to-source current decreases with increasing temperature at a fixed gate voltage, making it easier to connect multiple MOSFETs in parallel for higher power output.”

- Their on-state resistance R_{on} can be very low, often just a few milliohms, making them ideal for handling high currents without significant voltage drop. For Example, a current of 10A through in bipolar transistor like (2N3055) results in a drop voltage of approximately one volt, whereas in a MOSFET like IRF150 , the drop voltage is around 100 millivolts.”

- that’s why The use of MOSFETs transistor, instead of bipolar transistors, is ideal for our specific application.

2.3.6 How the Electronic Load Works

The power stage consists of a MOSFET, this later operates in its saturation region as a current generator controlled by Gate-Source voltage V_{gs} wich is the voltage of controle V_{com} in figure 2.3 . In this region, the drain-source current I_{DS} is expressed as follows:

$$I_{DS} = K_N(V_{GS} - V_{th})^2 \quad (2.1)$$

I_{DS} : current between Drain-Source

K_N : A constant that depends on the MOSFET’s physical and technological parameters

V_{th} : the threshold voltage.

When the voltage V_{GS} is less than $V_{th} - V_{DS}$, the MOSFET enters its ohmic region and behaves like a resistance controlled by the V_{GS} .

$$I_{DS} = K_N [2(V_{GS} - V_{th})(V_{DS} - V_{DS}^2)] \quad (2.2)$$

The operating point of the panel is located at the intersection of its characteristic curve and that of the MOSFET, as shown in Figure 2.4. For a given V_{GS} , the output characteristic is fixed. for this given V_{GS} we measure the current comes from the PV panel and the Voltage across it , to measure the current I_P and voltage V_P , which represent an operating point. By varying V_{GS} , we can then scan the entire characteristic curve of the panel. The variation of V_{GS} is controlled by the charging of a capacitor. In this case, there is no need to fix a specific operating point; rather, it only needs to vary from Q_{CC} point to Q_{CO} point . However, the speed at which the generator’s characteristic is traversed must be slow enough to allow sufficient time to acquire each pair I_P, V_P , corresponding to a specific operating point.

We can observe that the MOSFET’s operating zone is bounded by gray-colored regions, as shown in Figure 2.4. The first region exists because the MOSFET cannot conduct below a certain gate-source voltage V_{GS} threshold, known as V_{th} , preventing its characteristic curve from reaching the X-axis. The second region is due to the MOSFET’s on-state resistance $R_{DS(on)}$, even when saturated, which also limits its operating range.

Additionally, the maximum power that the load (and consequently the MOSFET) must dissipate corresponds to the maximum power the panel can deliver, denoted as P_m . Therefore, the selected MOSFET must be capable of handling this power dissipation. It is clear that the choice of MOSFET for the load implementation is a critical factor this choice we focus on the $I_{Ds} - V_{Ds}$ characteristics to ensure the use of the perfect MOSFET .

our choice its based on IRF150 by taking in consideration the $I_d - V_{GS}$ characteristic of MOSFET transistor We refer to the IRFP150 (MOSFET) datasheet, the $I_d - V_{GS}$ characteristic, is show in Figure 2.5.

by taking Two point A and B:

- **Point A:**

Assuming the maximum current through each MOSFET is 2.5A, the corresponding V_{GS} voltage is 4.25V.

- **Point B:**

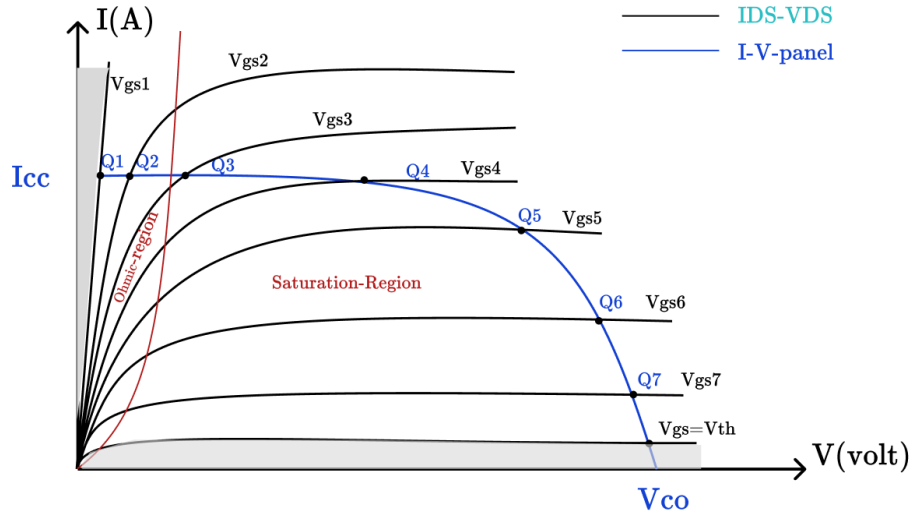

Figure 2.4: :Operating Principle of the Implemented Electronic Load.

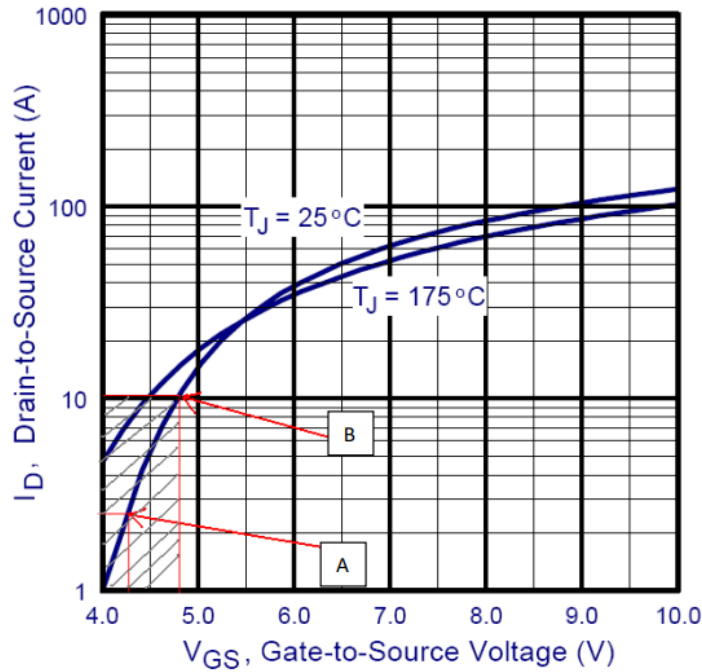

Figure 2.5: :Characteristic $I_d = f(V_{GS})$ IRFP150 .

Point B indicates that the voltage required to pass 10 A (current) is for V_{GS} (B) = 4.8V. For safety reason , we will set V_{GSmax} to 5V.

Thus, the voltage V_{GS} (t) must vary from 0V to 5V to allow the transistors to transition from a blocked state to a saturated state, enabling the current I_D to vary from 0 A to I_{sc} for the PV panel.

$$0 < V_{GS} < 5V \quad (2.3)$$

This variation must be sufficiently slow compared to the analog-to-digital converter acquisition times.

2.4 Measurement of PV characteristic ,Temperature and solar radiation

This part of the circuit is responsible for conditioning the current I_P and voltage V_P to prepare them for digitization. The block consists of three chains:

- Current Measurement Chain: This chain is dedicated to measuring the current delivered by the photovoltaic panel. The current is then fed into an A/D converter . This chain consists of a current sensor, followed by an adaptation stage.
- Voltage Measurement Chain: This chain is responsible for measuring the voltage V_P across the photovoltaic panel. This voltage is followed by an adaptation stage.
- Temperature Measurement Chain: This chain uses a digital sensor that communicates directly with the microcontroller (μC) to measure the temperature.
- Solar Radiation Measurement Chain: This chain also uses a digital sensor that communicates directly with the microcontroller (μC) to measure solar radiation.

2.5 Micro-controller

2.5.1 Definition

A micro-controller is an integrated circuit that combines a microprocessor, various types of memory, and communication peripherals (inputs and outputs) within a single package.

Unlike a microprocessor (μP), a micro-controller (μC) integrates the following components:

- ROM memory, primarily for storing the program.
- RAM memory, mainly for storing variables.
- Peripherals, to interact with external devices.
- A clock, which is typically external.

2.5.2 The Role of the Micro-controller

The micro-controller is the main component of the system, responsible for the following tasks:

- Controlling the electronic load.
- Communicate with all used sensors Reading and manages all measured data .
- Transmitting data to the TFT display and receives users instructions.

To perform these operations, the micro-controller must have several A/D converters (at least three) with sufficiently short conversion times to meet the requirements of this application.

2.6 Display screen

A thin-film-transistor liquid-crystal display (TFT LCD) is a type of liquid-crystal display that uses thin-film-transistor technology to improve image qualities such as addressability and contrast. A TFT LCD is an active matrix LCD, in contrast to passive matrix LCDs or simple, direct-driven (i.e. with segments directly connected to electronics outside the LCD) LCDs with a few segments.

TFT LCDs are used in television sets, computer monitors, mobile phones, video game systems, personal digital assistants, navigation systems, projectors, and dashboards in some automobiles and in medium to high end motorcycles.

this screen was utilized to ensure an optimal user experience.

2.7 power supply

The power supply is a crucial element of our setup, requiring good performance in terms of stability and regulation. Since the currents and voltages it needs to supply are relatively small (a few hundred milliamps) and ground isolation for each circuit, there is no need for excessive power capacity. It consists of the following sub-blocks (for more details please refer to chapter 3 and figure 3.2):

2.7.1 Input Power (220V AC)

The system receives a 220V alternating current (AC) from the main power source. This is the standard voltage used in many regions for household and industrial electricity.

2.7.2 Protection Circuit

The incoming 220V is first routed through a protection circuit. This is a crucial component designed to safeguard the system against power surges, short circuits, or other electrical faults that could damage the sensitive electronic components downstream.

2.7.3 Power Supply for Control Stage:

After passing through the protection circuit, the power is regulated and distributed. One output from the protection circuit feeds into a power supply for the control stage, which provides three specific voltage levels:

- 12V: Used for powering parts of the control circuit or other high-power components like (for FAN).
- 5V: Typically used for logic circuits and lower-powered devices, including certain digital electronics.
- 15V: Possibly intended for higher power components or specific analog circuits (Driver).

2.7.4 Power Supply for Sensors and ESP32

A separate power path, also fed through the protection circuit, supplies power specifically for the sensors and the ESP32 micro-controller. This section provides three different voltage levels:

- +5V: This is a common voltage for powering sensors and low-power micro-controller components.
- -15V: Negative voltages are often used in systems with operational amplifiers or other analog circuits where a bipolar power supply is needed (for sensors).
- +15V: This higher positive voltage may be used for additional analog components or specific sensor requirements (for sensors).

2.8 conclusion

In conclusion, the Curves tracer of PV panel is an essential tool for analyzing and optimizing solar panel performance. By accurately mapping I-V and P-V curves under various conditions

and utilizing advanced components like the ESP Wroom 32 micro-controller and MOSFETs, the PV tracer ensures precise data collection and efficient operation. This enables better understanding and improvement of solar panel efficiency and reliability. in the next chapter, we will provide a comprehensive overview of all the components of the device, detailing each part, the electrical circuits.

Chapter 3

Realization of PV Tracer

3.1 Introduction

In this chapter, we shift from theoretical discussions to the practical implementation of the PV curve tracer and its electronic boards. The realized PV curve tracer composed three main boards:

1. **Power Supply.**
2. **Voltage/Current Measurement and Power Stage.**
3. **Micro-controller, Temperature Measurement, Control, and Converter .**

Additionally, this chapter includes the presentation of the device's programming code, along with the performance test results that were conducted to verify its efficiency and effectiveness.

3.2 Power Supply Board

This electrical board encompasses what we previously discussed regarding the power supply card. (figure 3.1) illustrates the design of this board in detail, which we will explain below. (figure3.2) shows the actual final form of the printed circuit board that was created based on the design.

3.2.1 Protection Circuit and Transformer

To protect the components from high voltage and high current resulting from short circuits, we employed circuit protection. The protection components include a fuse for current protection and a varistor for voltage protection, as illustrated in Figure 3.1. A step-down transformer was used to reduce the input voltage from 220 volts to two isolated outputs of 22 volts. Isolation between the two outputs was implemented to protect the (ESP32) board from potential back currents..

3.2.2 Rectifier and Filter

The role of this stage is rectify the alternating current (AC) coming from the transformer into direct current (DC) by using (motioned the reference of circuit), two rectifiers were used, as

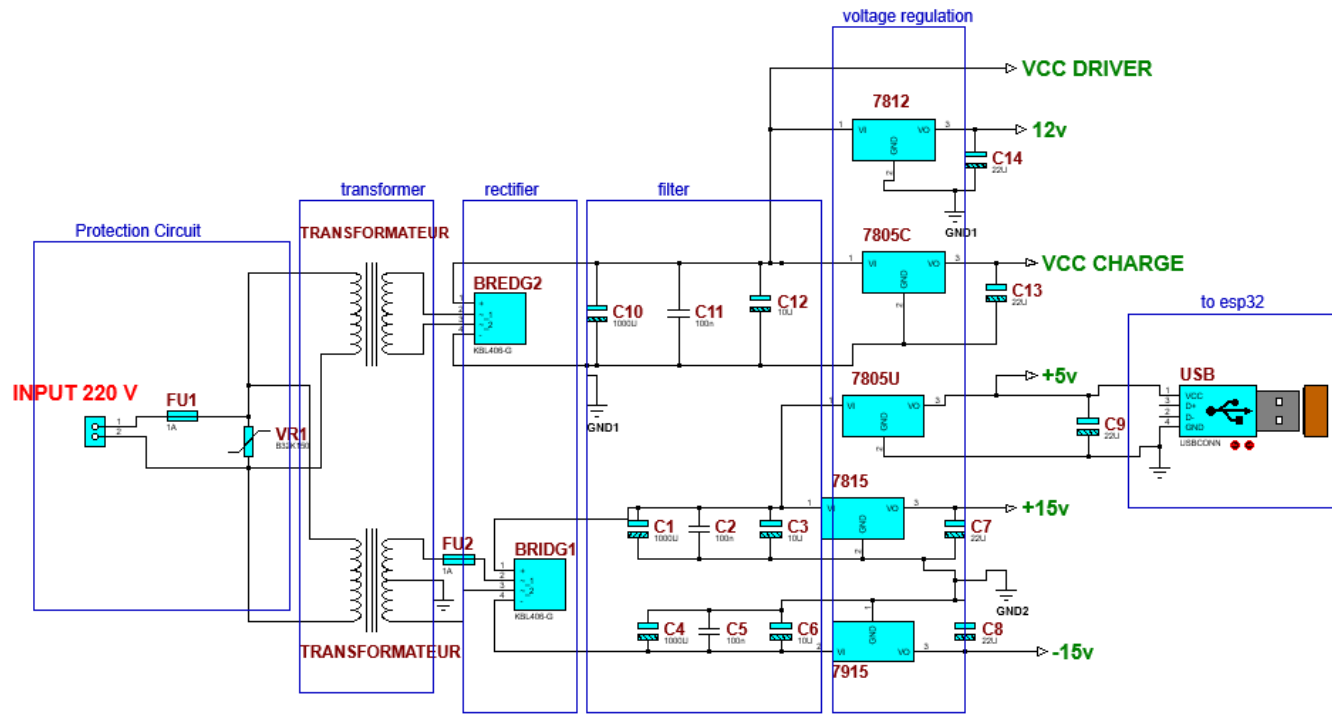

Figure 3.1: Schematic Diagram of the Power supply .

indicated in Figure 3.1, due to the presence of two isolated outputs in our device . Moreover, an additional stage has been added to filter the output signal from the rectifier stage using parallel capacitors.

3.2.3 Voltage Regulation

To ensure a stable voltage for powering the different stages of the realized device, multiple voltage regulators have been used, as shown in Figure3.1:

- 1- A regulator is used to generate +5 volts by employing the LM7805, which supplies the USB port. This port is utilized for powering the ESP32 card
- 2- The second regulator is used to provide a stable 5 volts to charge the capacitor, which controls the Vgs of the MOSFET transistor. The latter is used as the load for the PV panel
- 3- Two additional controllers, LM7812 and LM7809, have been used to supply the current and voltage sensors , LA25 & lv 25 respectively the final view of the realized power board figured in 3.2

3.2.4 Power Stage and Voltage/Current Measurement Board

In this board, represented in the figure3.3 , two main components were integrated: the **power stage** and the voltage and current measurements, due to their close interconnection. The power stage is represented by the MOSFET, which acts as a load for the photovoltaic panel. The panel voltage V_{pv} , which is the same as the MOSFET voltage V_{ds} , is measured using a voltage sensor. The current I_{pv} is measured using a current sensor and represents the total

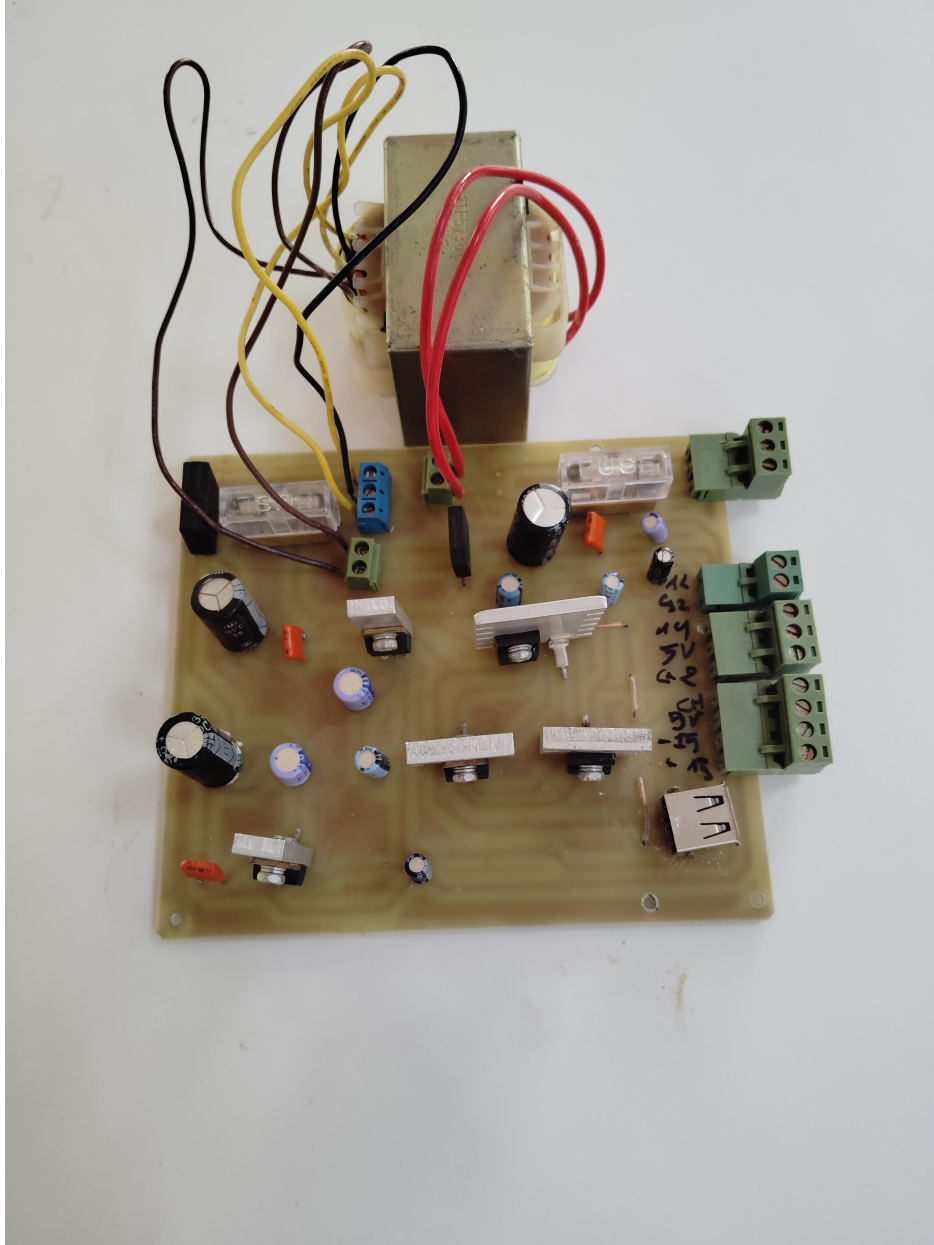

Figure 3.2: :The (PCB) of the power supply.

current passing through the MOSFETs. This integration ensures efficient power management along with accurate measurement of key performance parameters. Figure 3.4 represents the final realized board.

3.2.5 Power Stage

The power stage (as shown in the figure3.3) of the system is designed to function as a variable load for photovoltaic panels using IRFP150 MOSFETs. These MOSFETs operate in the Ohmic Region by controlling the gate-to-source voltage V_{gs} via a precise control stage. Four MOSFETs are connected in parallel to evenly distribute the total power of 500 watts, with each MOSFET handling 125 watts in this configuration. This ensures smooth operation without reaching maximum limits, reducing excessive heat, and extending the life

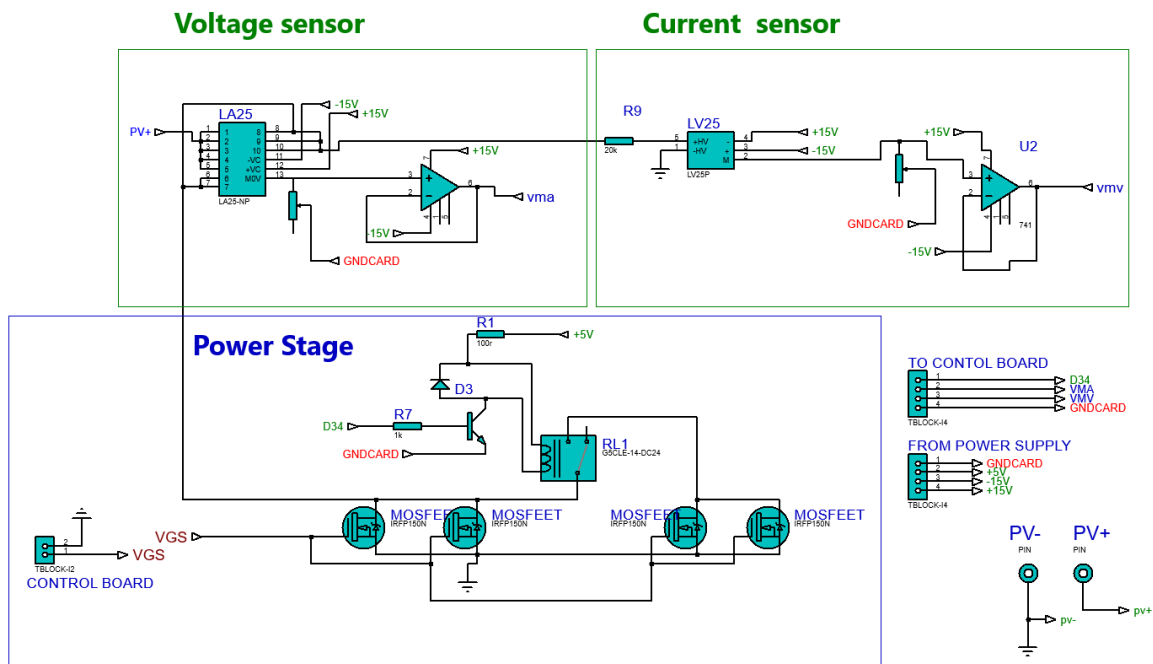

Figure 3.3: Schematic Diagram of the Power Stage and Voltage/Current Measurement

of the MOSFETs.

To manage varying power levels, a relay is employed to split the system into two stages: for low currents (less than 6 A), only MOSFET1 and MOSFET2 are active, with the relay remaining open. For higher currents (greater than 6 A), the relay closes, activating all four MOSFETs to ensure efficient load distribution.



Figure 3.4: :The (PCB) of the Power board

3.2.6 Voltage/Current Measurement

Voltage and current are measured using precise sensors and an analog-to-digital converter (ADC) to provide smooth control and response. The design emphasizes performance optimization and thermal stability by incorporating suitable heat sinks, enhancing reliability, and extending the system's operational lifespan.

Current Sensor (LA25-NP): The LA25-NP current sensor (figure 3.5) operates based on the Hall Effect, where the current passing through the conductor is converted into a magnetic field measured by a sensitive element within the sensor. The intensity of the magnetic field is then converted into an electrical voltage proportional to the current. The measurement voltage is determined using a variable resistor based on the transformer. The nominal secondary current of the sensor is 25 mA, and to obtain a measurement voltage of 4 V, the resistance should be 160 ohm (Figure 1.5). The sensor features electrical isolation between the primary and secondary circuits, ensuring safety. It can measure currents with accuracy up to 25 A, making it suitable for applications such as photovoltaic systems and transformers.

Voltage Sensor (LV-25P): The LV25 voltage sensor (figure 3.6) is a device based on the Hall Effect to measure voltage in electrical circuits. The sensor works by converting the applied voltage in the circuit into a measurable electrical signal. The primary voltage is determined by a resistor based on the primary current (10mA). The measurement voltage is also determined based on the secondary current (25mA) using a variable resistor. For

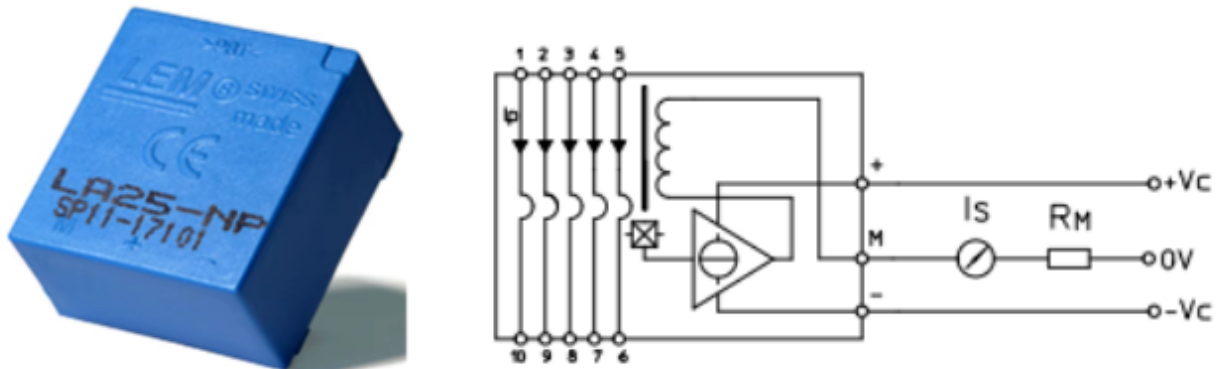

Figure 3.5: :LA25-NP current sensor

instance, to obtain an input voltage of 200V, the resistor should be 20kohm, and to get a measurement voltage of 4V, the variable resistor should be 160 ohm(figure1.6) .

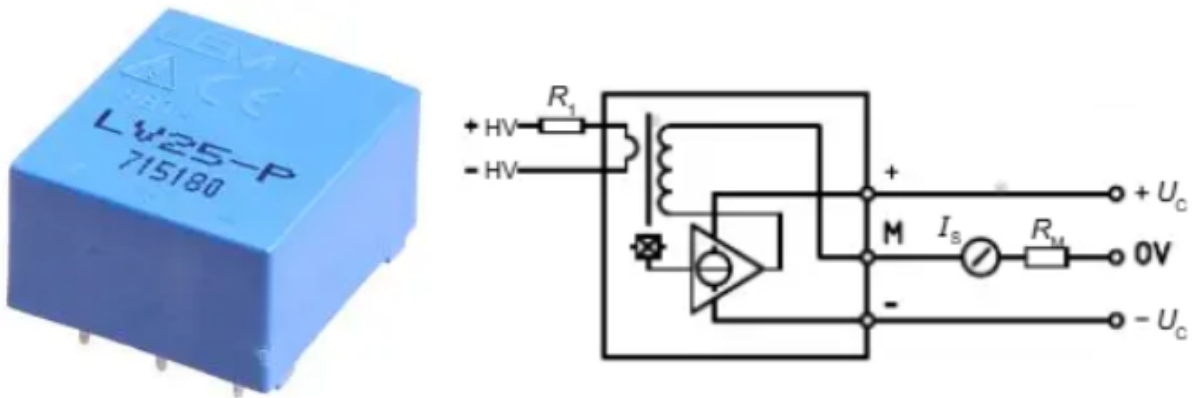

Figure 3.6: :LV25-P voltage sensor

3.3 Control Board

This board includes control, display , and temperature measurement (Figure 3.7). The control system is based on a micro-controller (ESP32), which serves several critical functions: controlling all MOSFETs, managing the display screen, and handling various measurements, including current, voltage, temperature, and solar irradiation. . Figure 3.8 represents the final realized board.

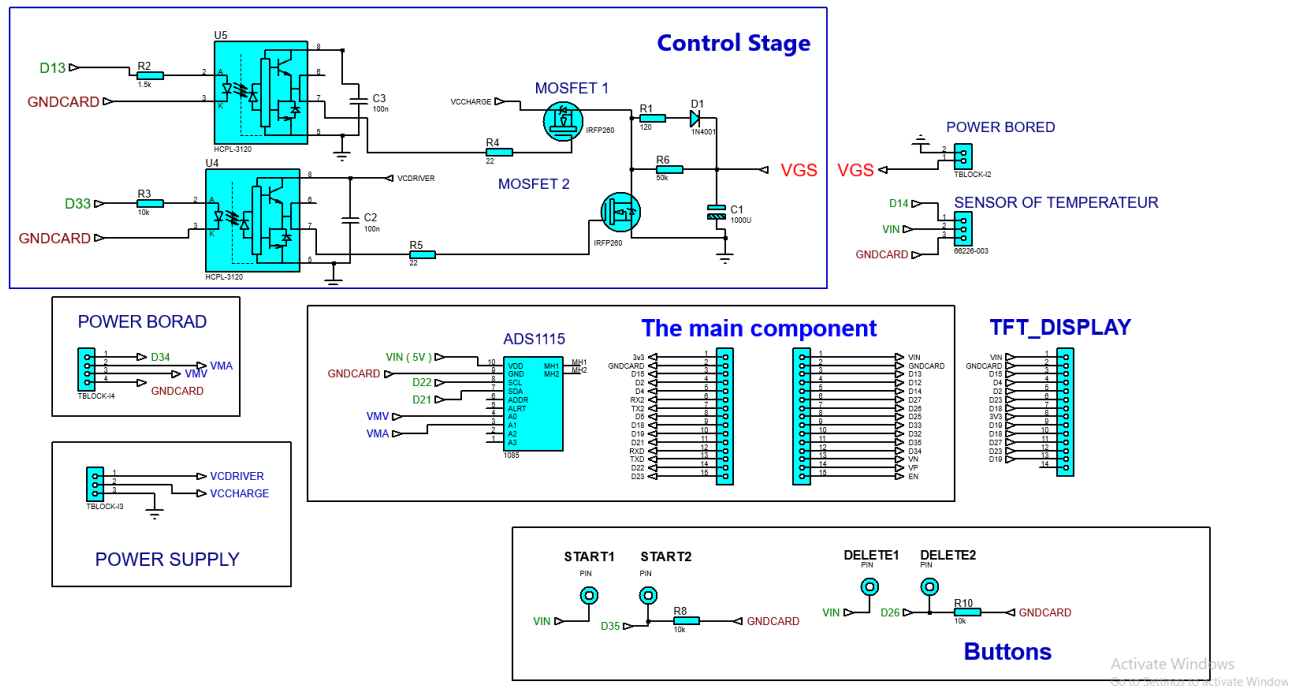

Figure 3.7: Schematic Diagram of the Control board

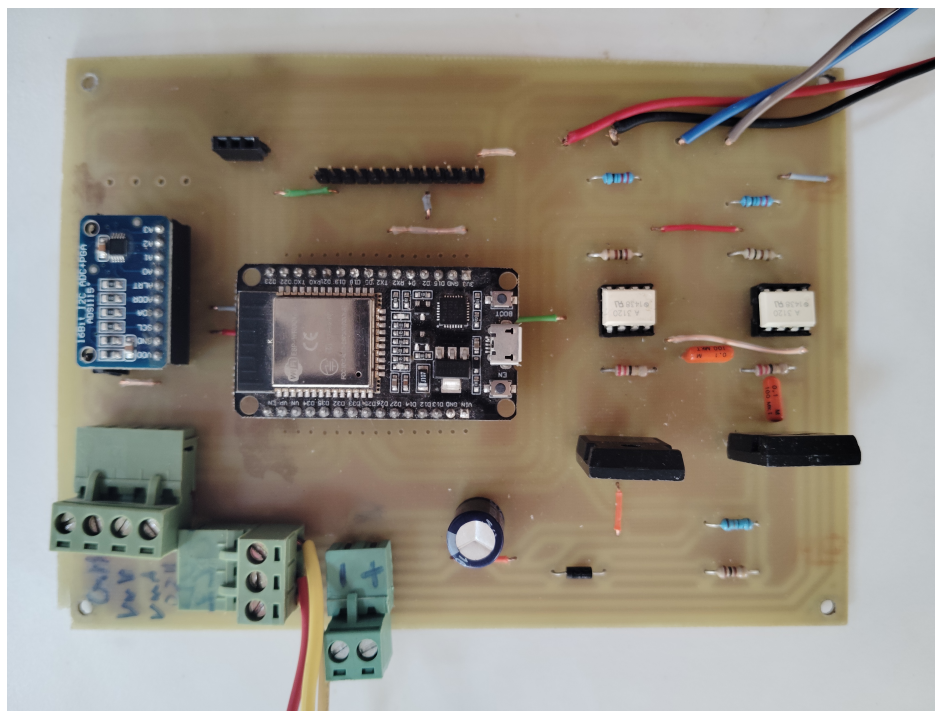

Figure 3.8: The (PCB) of the Control Board.

3.3.1 Micro-controller

The ESP32 card (figure 3.9) was chosen as the system's micro-controller, due to its features aligning with the system's requirements. The board has a large number of pins, a good clock speed, and is easy to program, along with a fast internal converter. It also has a large internal

memory and offers excellent performance at an affordable price, in addition to supporting Bluetooth and Wi-Fi connectivity. The board reads commands, controls the control stage and handles the power stage, reads voltage and current sensor values obtained from the ADS1115 converter, and directly reads the digital temperature sensor. It also plots curves based on the read values and exchanges data with the TFT-Display. The ESP32 board serves as the central hub for data management and control of all system operations.

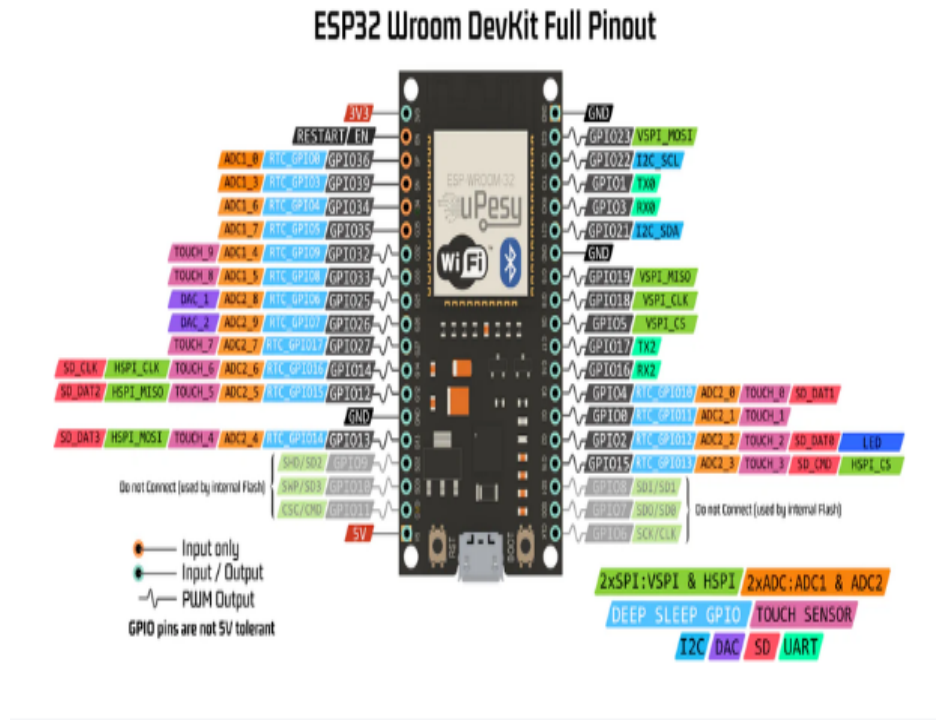

Figure 3.9: :ESP32 Wroom Card

3.3.2 Control Stage

In this section (figure3.10), the V_{gs} voltage, which corresponds to the capacitor voltage, is regulated by controlling its charging and discharging processes. This is achieved using MOSFET 1 and MOSFET 2, which act as switches for these operations. During the charging phase, MOSFET 1 is turned off, and MOSFET 2 is turned on, allowing the capacitor to charge through resistor R1. Conversely, during the discharging phase, MOSFET 1 is turned on, and MOSFET 2 is turned off, causing the capacitor to discharge through resistor R2.

The MOSFETs are controlled via optocouplers, which provide the necessary gate voltage to operate them as switches while ensuring electrical isolation between the ESP32 board and the power stage. MOSFET 1 is controlled using output pin D13, while MOSFET 2 is controlled using output pin D33. To optimize performance, R1 was selected with a small resistance value to enable rapid charging, while R2 was chosen with a larger resistance value, combined with the capacitor's capacitance, to achieve slow discharging. This design ensures compatibility with the response times of the sensors and the analog-to-digital converter (ADC)

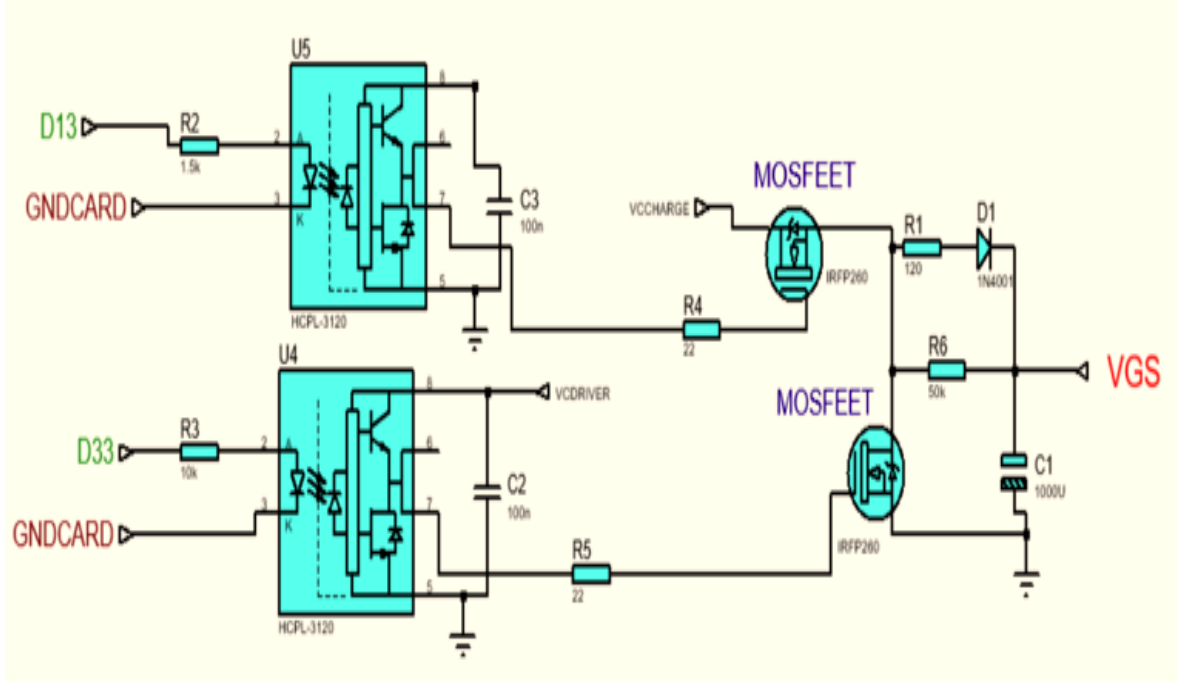

Figure 3.10: Schematic Diagram of the Control Stage

3.3.3 Measurement of Temperature

In this project, a thermocouple is employed as the temperature sensor. The converter sends a digital signal directly to the ESP32 via pin D14, where it is processed and displayed on the screen.

3.3.4 Analog-to-Digital Converter (ADC)

We used the **ADS1115** digital converter (figure 3.11) to convert the voltage and current sensor signals into digital signals. Although the **ESP32** board has an internal converter, its sensitivity to small values is very weak, which led us to use the **ADS1115** converter can read four signals and convert them with 16-bit precision, and it connects to the **ESP32** board via the **I2C** protocol.

3.4 The Display Screen and Software Interface

3.4.1 Display Screen TFT-Display

As mentioned in the previous section, the display screen acts as a bridge between the user and the realized device, presenting the software interface visually and converting it into pixels for easy interaction. It facilitates the input of solar panel data via touch and ensures seamless transmission of this information to the micro-controller ESP 32. Navigation between interfaces is also achieved through touch functionality.

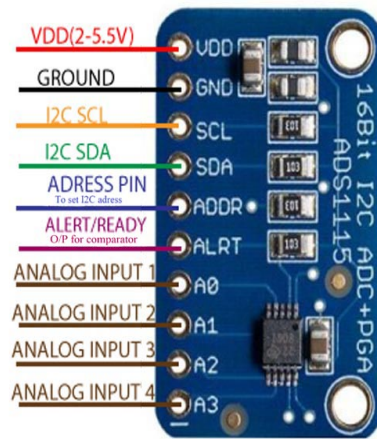

Figure 3.11: : The **ADS1115** Analog to Digital Converter



Figure 3.12: : TFT Display (ST77960)

3.4.2 Software Interface

The microcontroller was programmed using the C++ programming language (Arduino interface). The software system aims to efficiently organize and coordinate the operation of electronic components while maintaining performance and data processing speed. Figure 3.13 represents the control diagram of the software system.

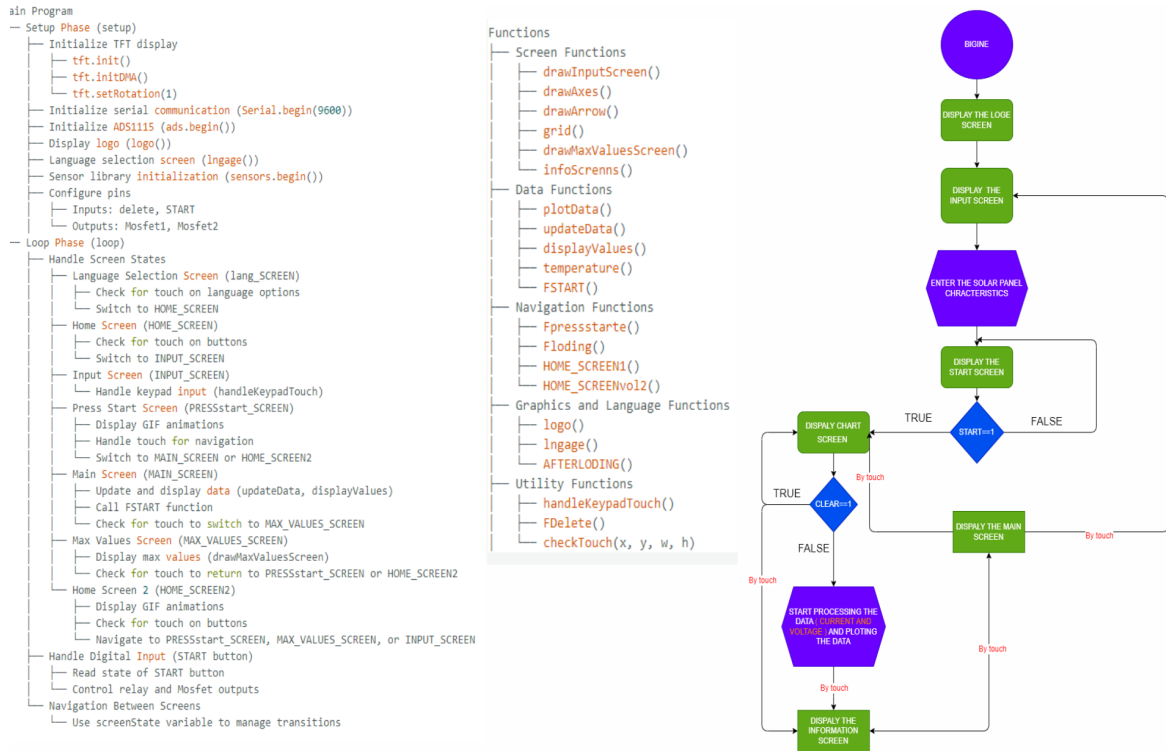

Figure 3.13: : Diagram of the software system

3.5 Tests of a PV Curve Tracer

In this section, we will outline the methods used to exploit and test the functionality of our developed device. This involves describing the experimental setup, the testing procedures, and the analysis of results to validate the performance and reliability of the PV tracer. The figure 3.14 represent the Front panel of PV tracer.



Figure 3.14: : The Front Panel of PV Tracer

The following figures illustrate the test results of the device on the photovoltaic panel shown in Figure 3.17, as well as the operating stages of the device, which proceed sequentially as follows:



Starting the PV tracer



language Select

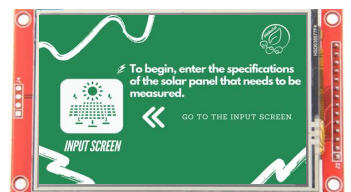

Go to input screen



Processing information

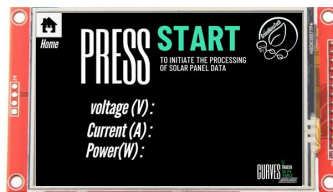

Press start

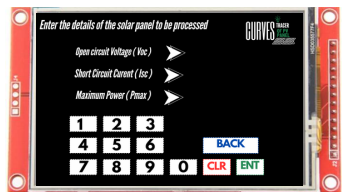

Interring the information

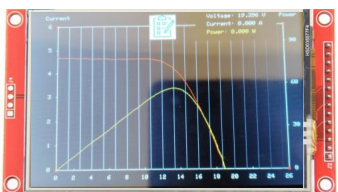

Plotting the curves



solar panel specifications		
Parameters	Value	
Maximum Power	Pmax	56.8 (W)
Open circuit Voltage	Voc	19.5 (V)
Short Circuit Current	Isc	4.7 (A)
Temperature / Irradiance	T and E	28.8 (°C) 942.2 (W/m²)
Rated Voltage	Vmpg	13.4 (V)
Rated Current	Impg	4.3 (A)

Displaying characteristics

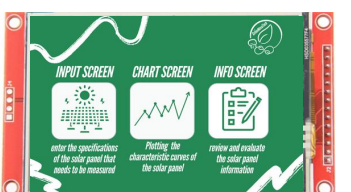

Home Screen



the used panel

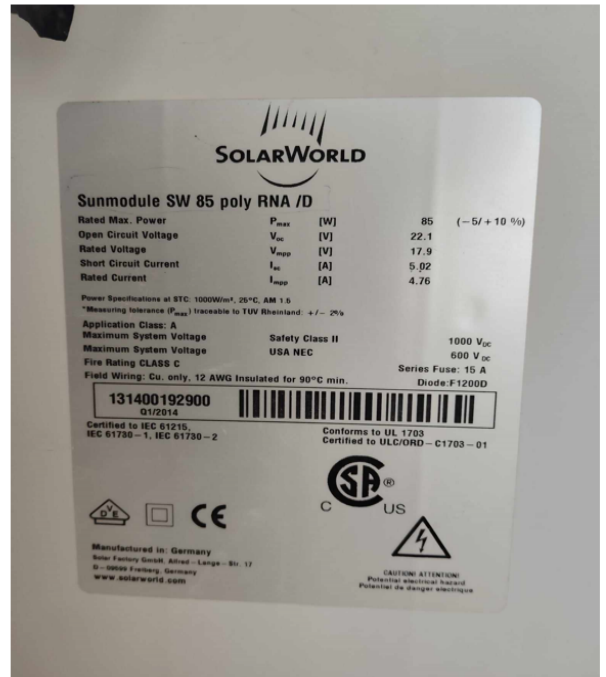

the information ticket

Figure 3.15: : External appearance of PV Tracer.

3.6 Prototype Overview

Preliminary Prototype of the Curved Trusses of PVT Project, The presented images show the initial prototype of our project. The prototype consists of several interconnected components:

3.6.1 Photovoltaic System Interface

A measurement system was designed to extract key electrical characteristics of a solar panel, including open-circuit voltage (V_{oc}), short-circuit current (I_{sc}), and maximum power point (P_{max}).

A sensor-based acquisition system was implemented to collect temperature and irradiance data, essential for evaluating system efficiency.

Electronic Control and Data Processing

The circuit includes microcontroller-based processing, which controls data acquisition and analysis.

A graphical touchscreen display provides real-time visualization of the IV (Current-Voltage) and PV (Power-Voltage) curves, facilitating performance evaluation.

Graphical Interface and User Interaction

The system incorporates an interactive touchscreen, allowing users to monitor solar panel specifications and characteristics.

Buttons for "Start" and "Clear" enable users to initiate measurements and reset the system when necessary.

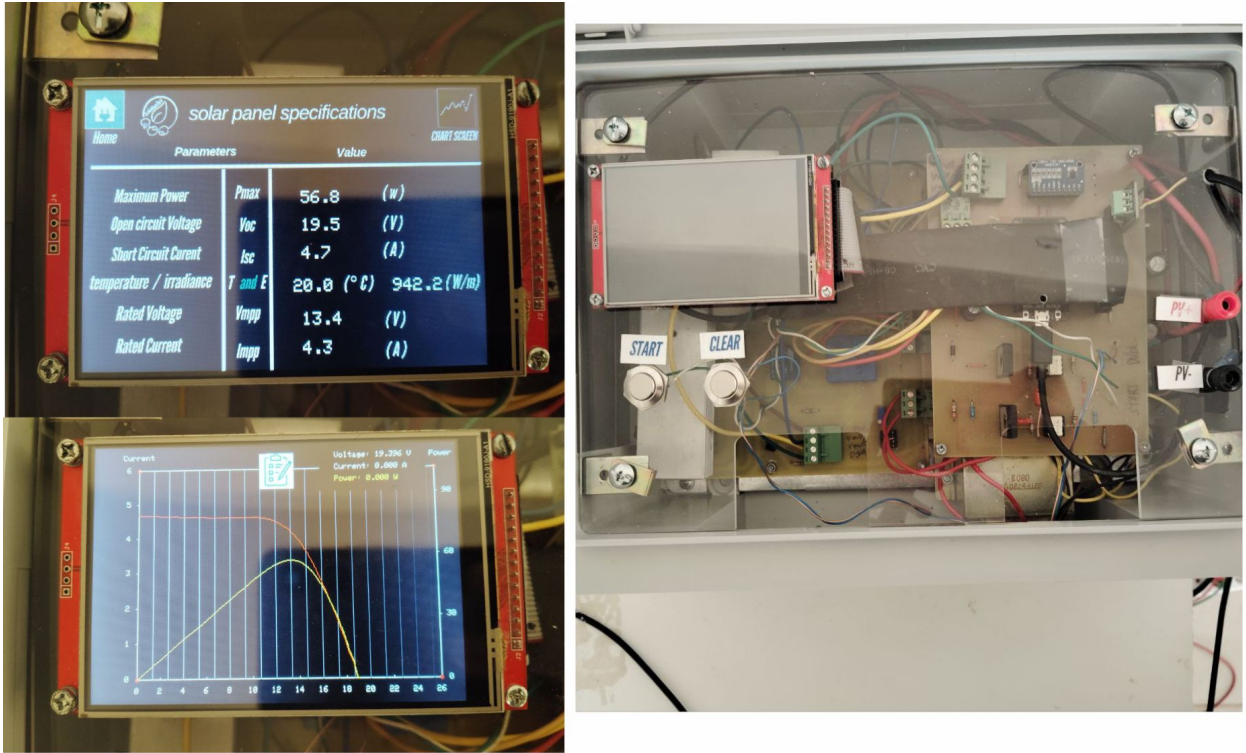

Figure 3.16: : External appearance of PV Tracer.

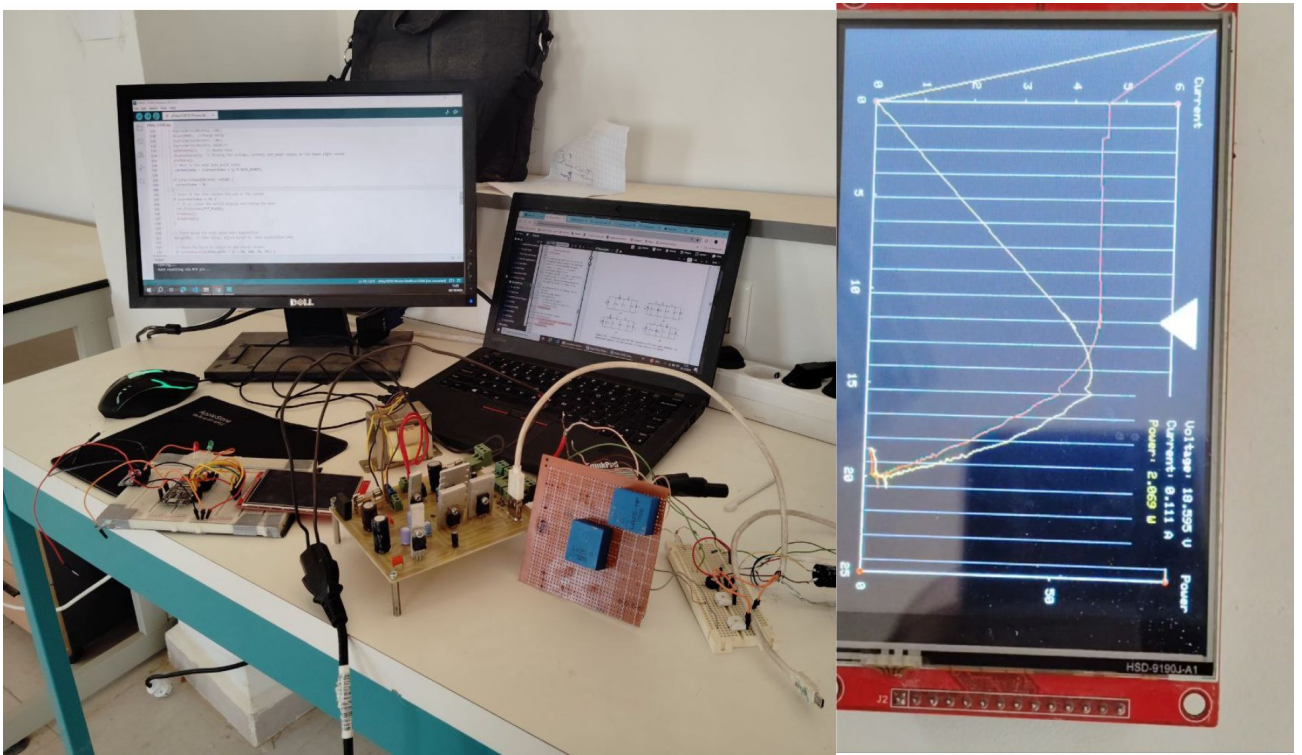

Figure 3.17: : the initial prototype of our project.

3.6.2 Challenges Faced

Despite the successful implementation of the prototype, several challenges emerged during development:

Measurement Accuracy Issues

Initial readings of voltage and current exhibited minor fluctuations due to sensor calibration errors.

The presence of electrical noise in the system affected data stability, requiring additional filtering techniques.

Software Optimization and Debugging

The real-time graphing functionality required extensive debugging to ensure smooth and accurate plotting.

The microcontroller code had to be optimized to handle data acquisition efficiently while preventing system crashes.

Hardware Integration Difficulties

The integration of multiple electronic boards resulted in unexpected power management issues, causing some modules to reset intermittently.

Soldering errors and weak connections led to occasional communication failures between system components.

3.6.3 Future Improvements

To enhance the prototype, future improvements will focus on:

Enhancing Sensor Calibration to improve measurement precision.

Implementing a More Robust Power Management System to prevent voltage drops and unexpected resets.

Optimizing the Data Processing Algorithm to reduce latency and improve real-time visualization.

This prototype serves as an essential step toward developing a reliable and efficient photovoltaic monitoring system, with continuous refinements planned for future iterations.

3.7 Conclusion

Chapter 3 outlines the complete realization of the PV Tracer, detailing the system's design and operational stages. The device effectively manages varying power levels with MOSFETs and relays for optimal load distribution. Accurate voltage and current measurements are achieved using high-precision sensors, ensuring reliable data collection for performance analysis. The ESP32 microcontroller plays a central role in system control, data processing, and display management. The TFT display facilitates user interaction, providing a seamless interface for data input and output. The testing stages confirm the device's ability to accurately plot the I-V characteristics of photovoltaic panels, making it a reliable tool for photovoltaic system analysis.

Economic Study of PV Tracer

4.1 Introduction

With the growing reliance on renewable energy sources, startups have become a driving force of innovation in the solar energy sector, necessitating the development of innovative solutions and tools to support this vital field. This project aims to design and develop a specialized device for tracking current-voltage (IV) curves of photovoltaic panels, a critical tool for evaluating panel performance and ensuring their operational efficiency. Analyzing and understanding IV curves is essential, as they provide precise data on panel efficiency, identify the maximum power point (MPP), and enable early detection of potential performance degradation over time.

The project is built on the integration of technical innovation with a clear commercial vision, introducing a device that is easy to use and allows researchers and technicians to measure, record, and analyze IV curves in real-time. This innovation contributes to enhancing maintenance efficiency and optimizing the use of solar panels in various energy applications. Furthermore, the project serves as a practical model for transforming technical ideas into economically viable products, promoting entrepreneurship and strengthening the position of startups in this promising sector.

Within this framework, this chapter aims to present a comprehensive business plan for the device, including a market study to ensure optimal project management. It involves showcasing the project concept, identifying innovative aspects, formulating market strategies, and developing a comprehensive financial plan to efficiently achieve the desired objectives.

4.2 Start-Up

Start-up Name:GreenNovaTech

Project Name:Curves Tracer of PV Panel

Industry Field:Renewable energies

Vision: Leading in the field of renewable energy and contributing to the development of local industries.

Headquarters: LAGHOUAT

4.3 Project Introduction

4.3.1 Project Idea(Proposed Solution)

Through this project, we seek to develop and keep pace with technology in the field of industry and renewable energy at the local and African levels, as we have noticed that regulation and researchers in this field face some problems, including accurate knowledge of the characteristics of photovoltaic panels.(I-V) In order to maintain it and know the effect of time on its performance, and Here came the idea of designing and implementing a photovoltaic panel curve tracker that would give real and accurate values and would be easy to use. We will produce a photovoltaic panel curve tracking device, by completing a production unit that relies on modern technology and specialized workers in the field, andMChoosing the area (Bouchaker-Laghout) because it is an industrial area.

4.3.2 Suggested Values:

In our device, values can be created Proposed and presented to customers through the following elements:

- The device gives a direct reading at the workplace without using a computer.
- Its ease and simplicity of use help users complete their tasks in a short time, and also contribute to the diversity of user segments.
- The ability to modify and change the product, making it adapt to the needs of users.
- Low production costs while maintaining performance to offer it at a reasonable price in the market.
- Providing product warranty and after-sales services to reduce customer concerns and gain their trust.
- The device is lightweight and has a modern design that makes it easy to carry around the workplace.

4.3.3 Work Team

The following table represents the project team and the role of each individual:

Tasks	Specialization	Team Members
Electronic circuit design and exterior design	Electronics	Student:SABBA Mokhtar
Consulting and Guidance	Electronics	Professor: ABOUCHABANA Nabil
Programming and Marketing	Electronics	Student:LAGRAA Souhil Zine Elabidine
Consulting and Guidance	Electronics	Professor: HADJAISSA Aboubakeur

Table 4.1: Team members and their tasks

4.3.4 Project Objectives

Through our product, we seek to expand and meet the needs of the local, African and global markets. We also seek to reach a market share estimated at 8%.0Percentage of the total imports to Algeria and the orientation towards export

4.3.5 Project Implementation Timeline

The following table represents the stages that the project goes through to start production in months:

Tasks	1	2	3	4	5	6	7	8	9	10	11
Preliminary study: location selection, required documents	•	•	•								
Request equipment from abroad		•	•	•							
Preparing the production site (factory)			•	•	•	•					
Equipment installation					•	•	•				
Raw material procurement						•	•	•			
Marketing the product before it is launched in the market							•	•	•		
The beginning of production of the first product									•	•	•

Table 4.2: The timeline for the start of production by months

4.4 Innovative Aspects

4.4.1 Nature of Innovations

The nature of innovationTOur product is diverse as follows:

Technological and Radical Innovations:

- Use of touch screen display type TFT.
- Enter information and read data and curves using the screen without resorting to a computer or other device.
- Ability to transfer information using WIFI.
- Taking real values for the data (not approximate values).

Market Innovations:

- Contribute to economic diversification and provide hard currency to the country.
- Strengthening the local market with local production.

Increasing Innovations:

- The possibility of developing and modifying the product according to customer requirements.
- Possibility of diversifying products in the field of electricity and renewable energy.

4.4.2 Areas of Innovation

The innovative aspects of our project are:

- The first product of its kind to be manufactured locally
- A product that contributes to facilitating and accelerating work for users such as maintenance and installation companies.
- Easy to use and lightweight, it will attract users to order it.
- Production of different types according to market needs

4.5 The Strategic Market Analysis

4.5.1 Market Segment View

- **Potential market for our product:** Universities and laboratories. The reason they buy this device is their research studies and laboratory work.
- **Target Market:** We seek to target a large number of photovoltaic energy production companies, panel production companies, as well as installation and maintenance companies. We have focused on these segments due to their need for this type of device to provide good services and products.

4.5.2 Measuring The Intensity of Competition

Market analysis of photovoltaic curve trackers indicates that there are a number of prominent companies in this field, such as: Fluke and Solmetric and Seaward, HT Instruments, etc. Each company offers distinct strengths and weaknesses:

Fluke:

- Strengths: Integrating advanced technologies following the acquisition of Solmetric, such as the PVA-1500HE that provides accurate and fast measurements.
- Weaknesses: Devices can be expensive and require specialized training for optimal use.

Solmetric:

- Strengths: Good reputation in the market for the accuracy of the analyzers and ease of use.
- Weaknesses: Limited direct technical support after Fluke acquisition.

Seaward:

- Strengths: Providing integrated testing and measurement equipment with advanced analysis features.
- Weaknesses: Some devices may be heavy and inconvenient for field transport.

HT Instruments:

- Strengths: Provides multi-functional and accurate devices.
- Weaknesses: Maintenance and technical support costs can be high.

The exact market shares of these companies are not directly available, but the general trend indicates a significant growth in the use of these devices as solar energy adoption expands globally. Companies such as Fluke gains significant share through advanced technology integration and strategic acquisitions of specialist companies

4.5.3 Marketing Strategy

For successful and effective marketing, we will work on all available methods to increase opportunities, including:

Market and target audience analysis:

- Identify the needs and behaviors of the target audience.
- Market and competitor research.

Determine marketing objectives:

- Set clear, specific, and measurable goals.

Create a brand identity:

- Define your logo, vision and values.
- Visual identity design.

Pricing strategy:

- Pricing is determined based on market research and value proposition

Promotion strategy:

- Digital Marketing (Social Media, SEO, Content, Email).
- Traditional marketing (TV and radio ads, print).
- Offering special offers and discounts.
- Writing scientific articles that attract specialists.

Customer interaction:

- Build strong relationships through ongoing communication.
- Providing excellent customer service.
- Open a space for complaints and customer feedback.

Performance measurement and analysis:

- Use analysis tools to evaluate performance and Adjust strategy based on data.

Continuous innovation:

- Keep up with the latest trends in the market and Continuously improve products and services.

4.5.4 Environmental Analysis SWOT

Strengths:

- Using advanced technologies in the device to improve the efficiency of photovoltaic panels and increase their yield.
- Providing a unique and innovative product in the local market.
- Having a highly skilled team in the fields of engineering, technology and renewable energy.
- Product Y Contribute to achieving environmental sustainability goals and reducing carbon emissions.

Weaknesses :

- Facing challenges in financing and rapid growth.
- Difficulty in building a strong reputation and gaining customer trust in the beginning.
- Lack of time and resources To continuously improve and develop products.
- may N Face challenges in complying with local and international standards and regulations.

Opportunities:

- Increasing demand for renewable energy in general and solar energy in particular.
- Providing incentives and support to companies working in the field of renewable energy and start-ups by the government.
- Possibility of expanding the market to other countries that need solar energy solutions.
- Possibility of forming partnerships with major solar energy companies and contractors.

Threats:

- Increased competition from other companies that produce similar technologies.
- Changes in government policies regarding renewable energy may impact the market.
- Global or local economic crises may affect customers' purchasing power and investments.
- The constant need to keep up with technological developments in this field can be a challenge.

4.5.5 Exit Strategy

In anticipation of the bankruptcy of the institution and the failure of the project, we have taken the following measures to emerge with the least possible damage, which are:

- Heading to solar energy maintenance.
- Installation of photovoltaic panels.
- Manufacture of photovoltaic panel accessories.
- Printed circuit board manufacturing.

4.6 Production and Organization

4.6.1 Production process

The product goes through six stages in the production chain:

Procurement of raw materials:

- Printed circuit boards, electronic components, product boxes and packaging boxes.

Printed circuit board manufacturing:

At this stage, the circuits designed by engineers are created using specialized programs. This stage goes through several processes, the most important of which are:

- Exposing the circuit boards to ultraviolet rays and then washing them with sodium hydroxide in order to remove the unwanted insulating layer.

-
- Corrosion process of the additional copper layer
 - Place insulating material on the board and drill holes for the electronic components.

Installation process:

- The electronic components are installed in their places and soldered, and then the circuit is installed in the external case designed for it.

Programming process:

- The micro-controller is programmed by engineers.

Testing and inspection process:

- In this process, the product is examined and the ones with errors and defects are sorted.

Packaging and packing process:

- The intact products are tightly packed and wrapped to maintain their safety.

4.6.2 Supply

We purchase raw materials (electronic components - printed circuit boards) from importers or manufacturing companies, depending on the possibility. We will also request device boxes and packaging boxes from local companies to provide them. We can also contract with local companies that produce printed circuits.

4.6.3 Labor Force

Our project allows for the provision of 5 initial job positions as follows:

- 02 engineers in the field of programming and electronics.
- 03 technician in the field of electricity and renewable energy.

4.6.4 Key partnerships

Among the most important partnerships that will contribute to development, enhance presence in the market and push the organization to success:

- Business incubator.
- Financing structures.
- Renewable energy companies and contractors.
- University research laboratories.

4.7 Financial Plan

4.7.1 Costs and Burdens

Preparing the headquarters:

- The headquarters costs us about 150,000 DZD to prepare according to the requirements of construction, painting and renovation.
- The cost of equipping the headquarters with desks, chairs, computers, papers, a printer and some other requirements is approximately 200,000 DZD.

Machinery and equipment:

The cost of machines and equipment, including laboratory tables, welding machines, drilling machines, packaging machines, and other machines, is approximately 2,000,000 DZD.

Raw material costs for one year:

If we estimate the production at 6 devices per month and 72 devices per year and the cost of raw materials per piece is 15,000 DZD, the cost of raw materials for the year will be approximately 1,080,000 DZD

Workers' wages:

Profession	Monthly income (DZD)	Annual income (DZD)	Number of workers	Total (DZD)
Technical	45,000	540,000	3	1,620,000
Engineer	60,000	720,000	2	1,440,000

Table 4.3: Workers' incomes

The total wages of workers during the year equals: 3,060,000 DZD

Additional costs

Additional costs include electricity, gas, water, internet subscriptions, rent and some other services, estimated at around 300,000 DZD per year. Marketing costs: Marketing costs are estimated at about 100,000 DZD in the first year.

4.7.2 Business Number

Turnover = Sales per year x Unit price + Additional revenue

4.7.3 . Expected Results Calculation Table

Number of sales per year	40 products
Unit price	70,000 DA
Services	600,000 DZD
Business number	3,400,000 DZD

Table 4.4: Sales and business number

Item	First year	Second year	Third year	Fourth year	Fifth year
Headquarters costs	350,000				
Machinery and equipment	2,000,000				
Raw materials	1,080,000	1,185,000	1,365,000	1,500,000	1,650,000
Wages	3,060,000	3,060,000	3,060,000	3,060,000	3,060,000
Additional costs	300,000	300,000	300,000	300,000	300,000
Stock	480,000	165,000	0	0	0
Sales	2,800,000	7,000,000	7,070,000	7,000,000	7,700,000
Services	600,000	660,000	730,000	750,000	750,000
Business number	3,400,000	7,660,000	7,800,000	7,750,000	8,450,000
Total cost of sales	3,960,000	4,860,000	4,875,000	4,860,000	5,010,000
Cost of services	2,000,000	2,200,000	2,500,000	2,500,000	2,700,000
Profit	760,000	2,580,000	2,675,000	2,640,000	3,170,000
Marketing costs	100,000	150,000	170,000	50,000	50,000
Additional expenses	50,000	150,000	170,000	170,000	170,000
Net profit	910,000	2,280,000	2,335,000	2,420,000	2,950,000

Table 4.5: Financial details over five years.

General Conclusion

This master project focused on the design and realization of a photovoltaic (PV) curve tracer using the characteristics of MOSFETs as a PV load and an ESP32 micro-controller for system control. The project successfully integrated multiple sensors, including current, voltage, and temperature sensors, to ensure accurate measurement and monitoring of key parameters of PV panels like I_{sc} , V_{oc} , I_{mpp} and V_{mpp} . A touch screen interface was implemented, providing an intuitive and user-friendly platform to operate and interact with the realized device.

The developed PV curve tracer demonstrates the ability to accurately trace the I-V and P-V characteristics of photovoltaic panels, making it a valuable tool for understanding and diagnosing PV performance under various conditions. The use of modern components and embedded systems ensured a compact and efficient design.

For future work, we recommend enhancing this device by incorporating advanced data exploitation and storage capabilities. By integrating features such as real-time data archiving and cloud-based analytics, the tool can provide more in-depth analysis and diagnostic capabilities. Such developments would improve its utility for researchers and practitioners working in renewable energy, supporting more comprehensive studies on PV performance and reliability. This project represents a significant step toward developing versatile, accessible, and efficient PV diagnostic tools.

Bibliography

- [1] Ahmad Rivai and Nasrudin Abd Rahim. A low-cost photovoltaic (pv) array monitoring system. In 2013 IEEE Conference on Clean Energy and Technology (CEAT), pages 169–174. IEEE, 2013.
- [2] Horacio Munguía Aguilar, Rigoberto Franco Maldonado, and Luis Barba Navarro. Charging a capacitor with a photovoltaic module. Physics Education, 52(4):045016, 2017.
- [3] Yingying Kuai and S Yuvarajan. An electronic load for testing photovoltaic panels. Journal of Power Sources, 154(1):308–313, 2006.
- [4] M Piliougine, J Carretero, L Mora-López, and M Sidrach-de Cardona. Experimental system for current–voltage curve measurement of photovoltaic modules under outdoor conditions. Progress in photovoltaics: research and applications, 19(5):591–602, 2011.
- [5] Thiago A Pereira, Lenon Schmitz, Walbermark M dos Santos, Denizar C Martins, and Roberto F Coelho. Design of a portable photovoltaic i–v curve tracer based on the dc–dc converter method. IEEE Journal of Photovoltaics, 11(2):552–560, 2021.