



People's Democratic Republic of Algeria  
Ministry of Higher Education and Scientific Research



## **Amar Thelidji University - Laghouat**

FACULTY OF TECHNOLOGY  
ELECTRONICS DEPARTMENT

### **MEMOIRE DE MASTER**

**Prepared by: Mechikel Elhocine and Abidi Salah Eddine**

**DOMAIN: Sciences and Technology**

**FILIERE: Telecommunication**

**OPTION: Telecommunication Systems**

### **Theme**

**5G Quality of Service (QoS)**

#### **Thesis Jury:**

<b>Name and Surname</b>	<b>Grade</b>	<b>Quality</b>
Ramdani Saadi	MCA	Supervisor
Seghire Abdelkrim	MAA	President
Merah lahcen	MAA	Examiner

**Promotion: 2020/2021**

# *Dedication*

*To my father Kadour,*

*for his patience and his considerable sacrifices ... these.*

*To my mother REBIHA that no dedication can express what I owe her.*

*To my brothers, MARZOUG and YASER,*

*To my sisters FATIMA and NADJET and NAIMA and her adorable little children.*

*To my friends IDRIS, DJAMEL, DADI, ESSEDIK, FATHI, ALI, ABDELHAFID*

*,MAHMOUD and HOCINE.*

*To my teachers,*

*To all those I love and all those who love me I dedicate this work*

***Salah Eddine***

## *Dedication*

*To whom I prefer, and why not;*

*To the one who sacrificed for me and spared no effort to always make me happy*

*To my beloved mother “Nadjat”.*

*As We walk in the path of life, it remains who controls our minds in every way we walk with the kind face and the good deeds.*

*To my dear father “Lakhder”.*

*The ones who stood next to me and helped me with all what they have, love, patience and encouragement.*

*To my dear brothers Yacine and Lahcene.*

*To my sisters ABIR, FATMA, SIHAM and her beautiful daughter DJANNA.*

*To my special friends Ali Elhoucine, Abdelnour, Mohamed, Sidahmed, Abdelhalim, Abdelhafid, Mahmoud, Med Bachir, Salah Eddine, Missoum, Khaled and all the friends that I met in the years of university.*

***Hocine***

## *Acknowledgment*

*At the end of this Honest work, we extend our thanks to all  
the persons who have contributed directly or indirectly so that we  
may complete this completion project.*

*We deeply thank Mr. S.RAMDANI for his quality supervision, the efforts he has  
made in trying to perfect our work, for his valuable help and advice and sympathy.*

*Our thanks also go to Mr. DADA IMAD for his leadership in the Transmition  
Centre and for all the information he has made available to us.*

*Our thanks also go to the members of the jury: to Mr Seghier Abdelkrim , Mr. ....  
for agreeing  
to examine our work.*

*Special thanks to all college workers and professors.*

*Finally, our thanking our families and especially our parents for us to have  
supported and to have done everything so that we can achieve an advanced stage  
of success. We will never be grateful enough to them.*

# List of Content

Dedication .....	
Dedication .....	
Acknowledgment .....	i
List of Content .....	ii
List of Figures .....	v
List of Tables .....	vi
abbreviations .....	vii
General introduction: .....	1
<b>Chapter I: New generations mobile networks technology .....</b>	<b>3</b>
1-Introduction: .....	3
2-4G Cellular Technology: .....	4
2-1-The User Equipment (UE) : .....	5
2-2-The E-UTRAN (The access network): .....	5
3-5G Cellular Technology: .....	8
3-1-Group cooperative relay: .....	9
3-2-Cognitive radio technology .....	9
3-3-Wireless mesh networks and dynamic Ad hoc networking.....	9
3-4-Smart antennas : .....	10
4-6G Cellular Technology: .....	13
5-Comparison of different cellular technologies: .....	15
6-Conclusion: .....	16
<b>Chapter II:Quality of service fordifferent mobile networks .....</b>	<b>18</b>
1-QoS GSM (2G): .....	18
1-1-Definition: .....	19
1-1-1- Indicators of service quality: .....	19
1-2- challenges faced throughout the procedures: .....	20
1-3-The measuring parameters are as follows: .....	22
1-4-The TEMS Investigation tool: .....	25
2- QoS 3G ( UMTS).....	27
2-1- Introduction.....	27

2-2- Definition of UMTS:.....	27
2-3- Architecture QoS global: .....	27
2-4- QoS classes in the UMTS network: .....	28
2-5- Quality-of-Service (QoS) management functions: .....	31
2-6- QoS characteristics: .....	34
3- QOS 4G LTE: .....	36
3-1- The concept of bearer: .....	37
3-2- The QoS parameters:.....	40
Conclusion:.....	44
<b>Chapter III: 5G quality of service .....</b>	<b>46</b>
1- 5G QoS: .....	46
2-5G Network's function: .....	47
2-1-AMF (Access and Mobility Management Function):.....	47
2-2-SMF (session management function): .....	49
2-3-UPF ( user plane function):.....	52
2-4- PCF (policy control function):.....	52
2-5- UDM (Unified data management): .....	52
2-6- AUSF (authentication server function):.....	53
2-7-NEF (network exposure function): .....	53
2-8-NRF (network repository function): .....	53
2-9-NSSF (network slice selection function): .....	54
3-PDU SESSION AND QOS FLOW: .....	54
3-1-PDU Session Establishment Message Sequence .....	54
4-5G QOS Architecture:.....	57
5- 5G QoS Flow to DRB Mapping: .....	58
6- 5G PROTOCOL LAYERS .....	59
7- Default QOS Flow: .....	60
8-QOS Types and Parameters: .....	61
8-1- 5G QoS Identifier (5GQI):.....	62
8-2-Allocation and Retention Priority (ARP):.....	62
8-3-Reflective QoS Attribute (RQA) : .....	63
8-4-Notification Control: .....	63

8-5-Flow Bit Rates: .....	64
8-6- Maximum Packet Loss Rate: .....	64
9- 5G QoS Flow Characteristics: .....	64
10- Standard values of 5QI: .....	65
11- 5G and 4G QoS Parameters Comparison: .....	66
12- Comparison between the LTE and 5G QoS architecture.....	68
Conclusion:.....	69
<b>Chapter IV: Simulation .....</b>	<b>71</b>
1- Objective:.....	71
2- Simulation Tool Matlab: .....	71
3- Simulation steps:.....	72
3-1- First case: .....	72
3-2- Second case: .....	72
3-4- Hybrid Weights Computation.....	75
3-4- Spectral Efficiency Comparison .....	78
General Conclusion.....	82
References.....	83
Abstract.....	85

## List of Figures

Figure 1: Basics LTE interfaces.....	5
Figure 2: E-UTRAN architecture.....	6
Figure 3: Evolved packet core architecture. ....	7
Figure 4: Features of 5G technology. ....	10
Figure 5: IP based 5G architecture.....	11
Figure 6: Basic 5G layer. ....	12
Figure 7: 5G master core.....	13
Figure 8: 6G network architecture. ....	14
Figure 9: Issues That arose throughout processes .....	21
Figure 10: SDCCH counter.....	23
Figure 11: Network coverage by RxLev.....	24
Figure 12: Correspondence between communication quality and BER the factors .....	25
Figure 13: QoS architecture in the UMTS network.....	28
Figure 14: QoS management functions in the control plan .....	31
Figure 15: QoS Management Functions in the User Plan.....	33
Figure 16: Need for QoS mechanisms when accessing shared resources .....	38
Figure 17: The EPS Bearer in the LTE/EPC System.....	39
Figure 18:5G network architecture .....	47
Figure 19: PDU Session Illustration .....	49
Figure 20: Illustration of GTP-U Tunnel between the Base Station and User Plane Function (UPF).....	51
Figure 21: SDF Template, QoS Profile and QoS Rule for UPF, gNB and UE respectively .....	55
Figure 22: UE- requested PDU Session Establishment for non-roaming and roaming with local	56
Figure 23: 5G QOS Architectur .....	58
Figure 24: QoS Flow to DRB Mapping.....	59
Figure 25: 5G PROTOCOL LAYERS .....	60
Figure 26: QOS Flow.....	60
Figure 27: QOS Types and Parameters.....	62
Figure 28: Standard values of 5QI.....	65
Figure 29: 5G and 4G QoS parametres Comparion.....	66
Figure 30: 5G and 4G QoS parametres Comparison architecture .....	68
Figure 31: Transmit and Receive (TR) module .....	72
Figure 32: Hybrid Beamforming Modul.....	73
Figure 33: First 3D Reponse pattern.....	77
Figure 34: Second 3D Reponse pattern .....	78
Figure 35: spectral efficiency Curve.....	81

## List of Tables

Table 1: Components of haplotypic variation and paired FST value .....	4
Table 2: Components of haplotypic variation and paired FST value for the 38 complete genome sequences of SARS-COV-2 from South America.....	15
Table 3: summarizes the QoS class characteristics of the UMTS network.: .....	30
Table 4: QCI Parameter Mapping Table.....	42
Table 5: 5G and 4G QoS Parameters.....	67

## abbreviations

**3GPP:** Third Generation Partnership Project

### A

**AF:** Application Functions

**AMF:** Access and Mobility Management Function

**APN-AMBR:** Access Point Name-Aggregated Maximum Bit Rate

**ARP:** Allocation and Retention Priority

**ARP:** Allocation and Retention Priority

**AUSF:** Authentication Server Function

### B

**BCCH:** Broadcast Control Channel

**BER:** Bits Error Rate

**BSC:** Base Station Controller

**BSS:** Base Station Sub-System

**BTS:** Base Transceiver Station

**BW:** Bandwidth

### C

**CN EDGE:** CN Enhanced Data Rate for GSM Evolution

**CS:** Circuit Switching

### D

**DCCH:** Dedicated Control Channel

**DL:** downlink

**DRB:** Data Radio Bearer

**DRB:** Data Radio Bearers

**DTCH:** Dedicated Traffic Channel

### E

**EPC:** Evolved Packet Core

**EPS:** Evolved Packet System

**ERAB:** for E-UTRAN Radio Access Bearer

**EU:** user equipment

**E-UTRAN:** Evolved UMTS Terrestrial Radio Access Network

### F

**FER:** Frames Erasure Rate

### G

**GBR:** Guaranteed Bit Rate

**GBR:** Guaranteed Bit Rate

**GFBR:** Guaranteed Flow Bit Rate

**GPRS:** General Packet Radio Service

**GTP:** GPRS Tunneling Protocol

**GTP-U:** GPRS Tunneling Protocol User Plane

### H

**HARQ :** Hybrid Automatic Repeat request

### I

**IE :** Information Elements

**ITU :** Union internationale des télécommunications

### K

**KPI:** Key performance indicators

### M

**MAC:** Medium Access Control

**MBR:** Maximum Bit Rate

**MDBV:** Maximum Data Burst Volume

**MFBR:** Maximum Flow Bit Rate

**MME:** Mobility Management Entity

**MT:** mobile terminal

**N**

**NAS:** Non Access Stratum

**NAS:** Non Access Stratum

**NEF:** network exposure function

**NGAP:** Next Generation Application Protocol

**NRF:** network repository function

**NSI:** Network Slice Instance

**NSSF:** network slice selection function

**O**

**OMC:** Operation Management Center

**P**

**PCF:** policy control function

**PDB:** Packet Delay Budget

**PDCP:** Packet Data Convergence Protocol

**PDP:** Packet Data Protocol

**PDU:** Packet Data Unit

**PDU:** Protocol Data Unit

**PELR:** Packet Error Loss Rate

**PER:** Packet Error Rate

**P-GW:** PDN Gateway

**PS:** Packet Switching

**Q**

**QCI :** QoS Class Identifier

**QFI :** QoS Flow Identifier

**QI :** QoS Identifier

**QoS:** Quality of Service

**R**

**RAB:** Radio Access Bearer

**RAN:** Radio Access Network

**RLC:** Radio Link Control

**RM:** Registration Management

**RQA:** Reflective QoS Attribute

**RQI:** the Reflective QoS Indicator

**RRC:** Radio Resource Control

**RRC:** Radio Resource Control

**S**

**SAP:** Service Access Point

**SBA:** Service-Based Architecture

**SCEF:** Service Capability Exposure Functions

**SDCCH:** Standalone Dedicated Control Channel  
**SACCH:** Slow Associated Control Channel

**SDF:** Service Data Flows

**SDU:** Service Data Unit

**SGSN:** Serving GPRS Support Node

**S-GW:** Serving Gateway

**SMF:** session management function

**SRB:** Signaling Radio Bearer

**SRB :**for Signaling Radio Bearer

**T**

**TCH:** Traffic Channel

**TEID:** Tunnel Endpoint Identifier

## **U**

**UDM:** Unified data management

**UDR:** Unified Data Repository

**UEAMBR:** User Equipment- Aggregated  
Maximum Bit Rate

**UL:** uplink

**UP:** User Plane

**UPF:** User Plane Function

**UTRAN:** UMTS Terrestrial Radio Access  
Network

## **V**

**VPLMN:** Visited Public Land Mobile  
Network

### **General introduction:**

A cellular network or mobile network is a communication network where the last link is wireless. The network is distributed over land areas called cells, each served by at least one fixed-location transceiver.

Mobile networks have evolved through a series of generations, each representing significant technological improvements over the previous generations. The first two generations of mobile networks first introduced analog voice (1G) and then digital voice (2G). Subsequent generations supported the proliferation of smartphones by introducing data connections (3G) and allowing access to the internet. 4G service networks improved data connections, making them faster, better and able to provide greater bandwidth for uses such as streaming.

Today, 5G stands for 5th Generation Mobile technology and is going to be a new revolution in mobile market which has changed the means to use cell phones within very high bandwidth. User never experienced ever before such high value technology which includes all type of advance features and 5G technology will be most powerful and in huge demand in near future.

In the field of telecommunications, QoS (Quality of Service) refers to the capacity of a comply with the requirements for the provision of a type of telecommunications service, in particular in Accessibility, Availability, Continuity and Integrity.

Indeed, the assessment of the state of the network, the detection of malfunctions and the analysis are essential tasks for the operator to have control over the network and carry out its maintenance actions and interventions.

Mobile networks in general have a special feature compared to fixed networks especially when it comes to evaluating its performance. The term quality of service has a specific meaning in the world of mobile network communication. It relates to the profitability and reliability of network and its services.

**Chapter I:**  
**New generations mobile networks**  
**technology**

## **Chapter I: New generations mobile networks technology**

### **1- Introduction:**

The mobile communication systems and the wireless communication technologies have been proving very fast day by day. Wireless communication is the transfer of information over a distance without the use of enhanced electrical conductors or "wires" When the context is clear, the term is often shortened to "wireless" It encompasses various types of fixed, mobile, and portable two-way radios, cellular telephones, Personal Digital Assistants (PDAs), and wireless networking [1].

In the past few decades, the mobile wireless technologies have experience of various generations of technology revolution and evolution, namely from 0G to 4G. Currently and on future, we are exposing to new cellular generations namely 5G, 6G, 7G, 8G and etc. Consumers are demanding more advanced and useful applications. Each generation has some standards, capacities, techniques and new features which differentiate it from previous generations. Due to these new features, the number of mobile phone subscribers is increasing day by day. Hence, there is need of capacity improvements in wireless communications.

The 4G integrates 3G with fixed Internet to support wireless mobile Internet, which is an evolution to overcome the limitations of 3G and also raises the QoS, increases the bandwidth and reduces the cost of resources. The 5G brings forward a real wireless world-Wireless World Wide Web (WWW) while 6G is proposed to integrate 5G with satellite networks for global coverage. 7G deals with space roaming. The paper is organized in five sections followed by conclusion, recommendation. Section II describes about 4G cellular technologies in detail. Section III gives a detailed explanation about 5G cellular networks. Section IV and V talks about 6G and 7G cellular technologies respectively and section VI gives a detailed comparison of 4G, 5G, 6G, and 7G of cellular technologies.

## **2- 4G Cellular Technology:**

4G is an IP-based technology that uses voice communication. LTE (Long Term Evolution), UMB (Ultra Mobile Broadband) and the IEEE 802.16 (WiMAX) are considered to be 4G standards [2].

<b>Network</b>	<b>Peak value of download</b>	<b>Peak value of upload</b>
<b>LTE</b>	100 Mbit/s	50 Mbit/s
<b>LTE advanced</b>	1000 Mbps	500 Mbps
<b>WiMAX</b>	128 Mbit/s	56 Mbit/s

***Table 1: Components of haplotypic variation and paired FST value***

Mobile Web access, IP telephony, gaming services, High Definition (HD) mobile TV, video conferencing, and 3D television are the applications of 4G cellular networks.

The first release of LTE (Long Term Evolution) standard has been commercially deployed in 4G does not support circuit-switched networks but it is an IP-based network system. 4G networks are the pillars as it integrates several radio access networks with fixed Internet networks [3].

In 2009, the ITU-R organization specified the IMT-Advanced (International Mobile Telecommunications Advanced) requirements for 4G standards, setting peak speed requirements for 4G service at 100 Mbit/sec for high mobility communication (such as from trains and cars) and 1 Gbit/sec low mobility communication (such as pedestrians and stationary users). One of the key technologies for 4G and beyond is called Open Wireless Architecture (OWA), supporting multiple wireless air interfaces in an open architecture platform 4G is used also Software Defined Radio (SDR) as one of its technologies. SDR is used to configure or define the radio and make a common platform which can be used across a number of areas. And, it will develop a multi-band, multi-standard base stations and terminals. In future, the terminal will adapt the air interface to the available radio access technology, at present this is done by the infrastructure [4].

The high-level network architecture of LTE is comprised of following three main components: the User Equipment (UE), the Evolved UMTS Terrestrial Radio Access Network

(E-UTRAN) and the Evolved Packet Core (EPC) respectively. The evolved packet core communicates with packet data networks in the outside world such as the internet, private corporate networks or the IP multimedia subsystem. The interfaces between the different parts of the system are denoted Uu, S1, and SGi .

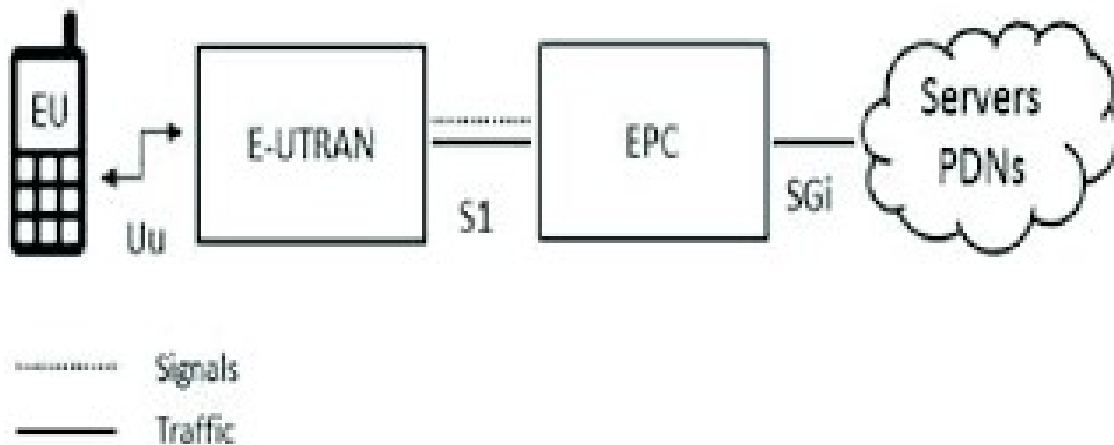

*Figure 1: Basics LTE interfaces*

### **2-1-The User Equipment (UE) :**

The internal architecture of the user equipment for LTE is identical to the one used by UMTS and GSM which is actually a Mobile Equipment (ME). The mobile equipment comprised of the following important modules:

- Mobile Termination (MT): This handles all the communication functions.
- Terminal Equipment (TE): These terminals the data streams.
- Universal Integrated Circuit Card (UICC): This is also known as the SIM card for LTE equipment. It runs an application known as the Universal Subscriber Identity Module (USIM). A USIM stores user-specific data very similar to 3G SIM card. This keeps information about the user's phone number, home network identity and security keys etc.

### **2-2-The E-UTRAN (The access network):**

The architecture of evolved UMTS Terrestrial Radio Access Network (E-UTRAN) has been illustrated in Figure 2.

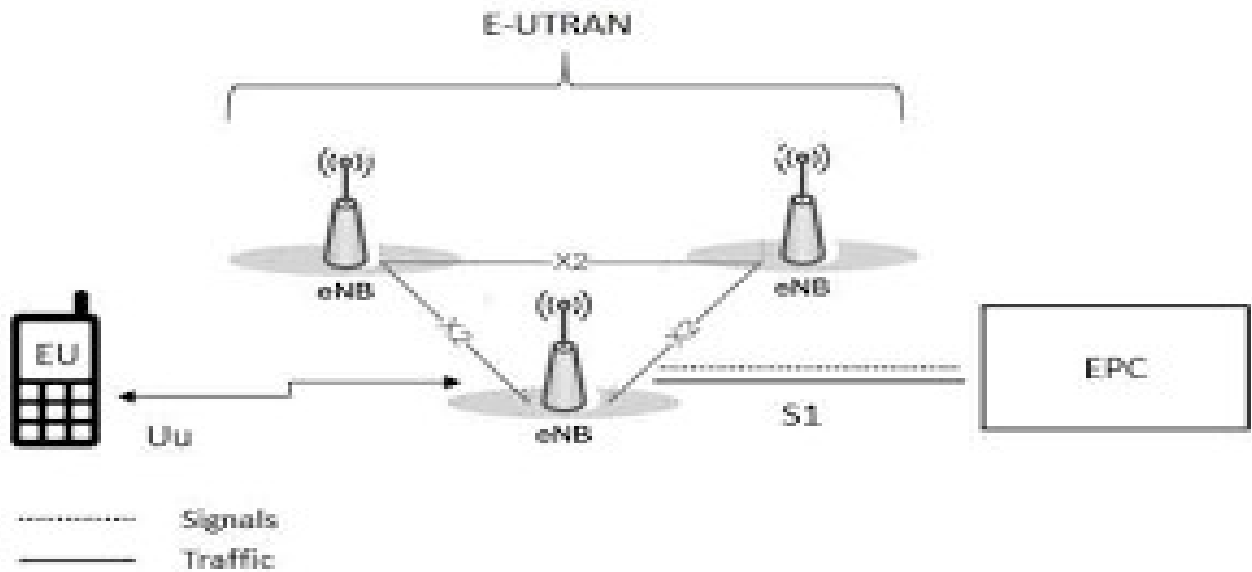

**Figure 2: E-UTRAN architecture.**

The E-UTRAN handles the radio communications between the mobile and the evolved packet core and just has one component, the evolved base stations, called eNodeB or eNB. Each eNB is a base station that controls the mobiles in one or more cells. The base station that is communicating with a mobile is known as its serving eNB. LTE Mobile communicates with just one base station and one cell at a time and there are following two main functions supported by eNB:

- The eNB sends and receives radio transmissions to all the mobiles using the analogue and digital signal processing functions of the LTE air interface.
- The eNB controls the low-level operation of all its mobiles, by sending them signaling messages such as handover commands.

Each eNB connects with the EPC by means of the S1 interface and it can also be connected to nearby base stations by the X2 interface, which is mainly used for signaling and packet forwarding during handover. A home eNB (HeNB) is a base station that has been purchased by a user to provide femtocell coverage within the home. A home eNB belongs to a closed subscriber group (CSG) and can only be accessed by mobiles with a USIM that also belongs to the closed subscriber group.

### The Evolved Packet Core (EPC-The core network):

The architecture of Evolved Packet Core (EPC) has been illustrated below. There are few more components which have not been shown in the diagram to keep it simple. These components are like the Earthquake and Tsunami Warning System (ETWS), the Equipment Identity Register (EIR) and Policy Control and Charging Rules Function (PCRF).

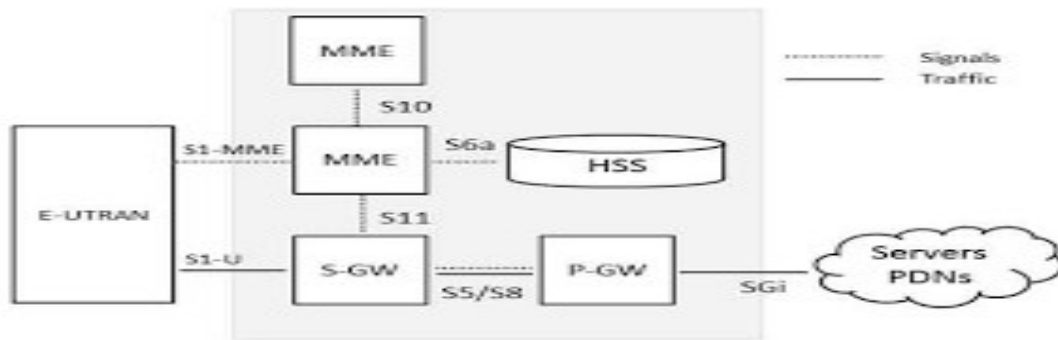

*Figure 3: Evolved packet core architecture.*

There is a brief description of each of the components shown in the above architecture:

- The Home Subscriber Server (HSS) component has been carried forward from UMTS and GSM and is a central database that contains information about all the network operator's subscribers.
- The Packet Data Network (PDN) Gateway (P-GW) communicates with the outside world i.e. Packet data networks PDN, using SGi interface. Each packet data network is identified by an access point name (APN). The PDN gateway has the same role as the GPRS support node (GGSN) and the serving GPRS support node (SGSN) with UMTS and GSM.
- The serving gateway (S-GW) acts as a router, and forwards data between the base station and the PDN gateway.
- The Policy Control and Charging Rules Function (PCRF) is a component which is not shown in the above diagram but it is responsible for policy control decision-making, as well as for controlling the flow-based charging functionalities in the Policy Control Enforcement Function (PCEF), which resides in the P-GW.

The interface between the serving and PDN gateways is known as S5/S8. This has two slightly different implementations, namely S5 if the two devices are in the same network, and S8 if they are in different networks.

### 3- 5G Cellular Technology:

5G mobile network is progressive version of the present 4G/IMT-Advanced standards since 2011. 5G (5th generation mobile networks or 5th generation wireless systems) is a name which used to denote the next major phase of mobile telecommunications standards, new standard releases beyond 4G are in progress by standardization bodies, but are at this not considered as new mobile generations but under the 4G umbrella.

The capacity of the 5G is aimed to be much higher than current 4G. Higher capacity would allow higher density of mobile users, ultra-reliability and massive communications. Also, research that is going on 5G aims at lower suspension and low battery consumption. 5G is designed for WWW (World Wide Wireless Web) and IPv6 is a fundamental protocol used to 4G and 5G cellular networks but since IPv6 assigns any IP address to any mobile node based on location management; therefore, this would cause wastage of 5G resources. According to the resources [6], 5G would get implemented around the year 2020. It has been noted that a new generation has appeared after every 10th year since 1G cellular network was introduced in 1981, 2G in 1992, 3G was in 2001 whereas 4G came into the market in 2012-2013

5G core concept would possess three technologies:

- Nano technology
- Cloud computing and,
- All flat IP platform

The 5th wireless mobile Internet networks are real wireless world which shall be supported by LAS-CDMA, OFDM, MC-CDMA, UWB, Network-LMDS and IPv6. IPv6 is a basic protocol for running on both 4G and 5G. Moreover, to solve the wasting of 5G resources due to IPv6 working nature (location management) and 5G aim (WWW based on network access management), the proposed the bandwidth optimization control protocol and the mix-bandwidth data path for future 5G real wireless world. The Bandwidth Optimization Control Protocol

(BDPC) is implemented in between MAC layer and TCP/IP layer, which is used to establish the mix-bandwidth. [7]

New mobile generations are typically assigned new frequency bands and wider spectral bandwidth per frequency channel (1G up to 30 kHz, 2G up to 200 kHz, 3G up to 5 MHz, and 4G up to 40 MHz), but sceptics argue that there is little room for new frequency bands or larger channel bandwidths. From users' point of view, previous mobile generations have implied substantial increase in peak bit-rate (i.e. physical layer net bit-rates for short-distance communication). However, no source suggests 5G peak download and upload rates of more than the 1 Gbps to be offered by ITU-R's definition of 4G systems. If 5G appears, and reflects these prognoses, the major difference from a user point of view between 4G and 5G techniques must be something else than increased maximum throughput. For example lower battery consumption, lower outage probability (better coverage), high bit rates in larger portions of the coverage area, cheaper or no traffic fees due to low infrastructure deployment costs, or higher aggregate capacity for many simultaneous users (i.e., higher system level spectral efficiency).

The ultimate goal of 5G is to offer 20 Mbps data rates, even when used in such scenarios as a vehicle traveling 200 kilometers per hour. And, it will support the fixed wireless networks [8]

Besides, 5G technology also used new computing concepts as follows: Pervasive networks A user can concurrently be connected to several wireless access technologies and seamlessly move between them.

### **3-1-Group cooperative relay:**

To make a high data rates available over a wider area of the cell. Currently, data rates fall towards the cell edge where interference levels are higher and signal levels lower.

### **3-2-Cognitive radio technology**

The user equipment/handset to look at the radio landscape in which it is located and choose the optimum radio access network, modulation scheme and other parameters to configure itself to gain the best connection and optimum performance.

### **3-3-Wireless mesh networks and dynamic Ad hoc networking**

By using a variety of different access schemes, it will be possible to link to others nearby to provide ad-hoc wireless networks for much speedier data flows

**3-4-Smart antennas :**

By using smart antennas, it will be possible to alert the beam direction to enable more direct communications, limit interference and increase overall cell capacity .

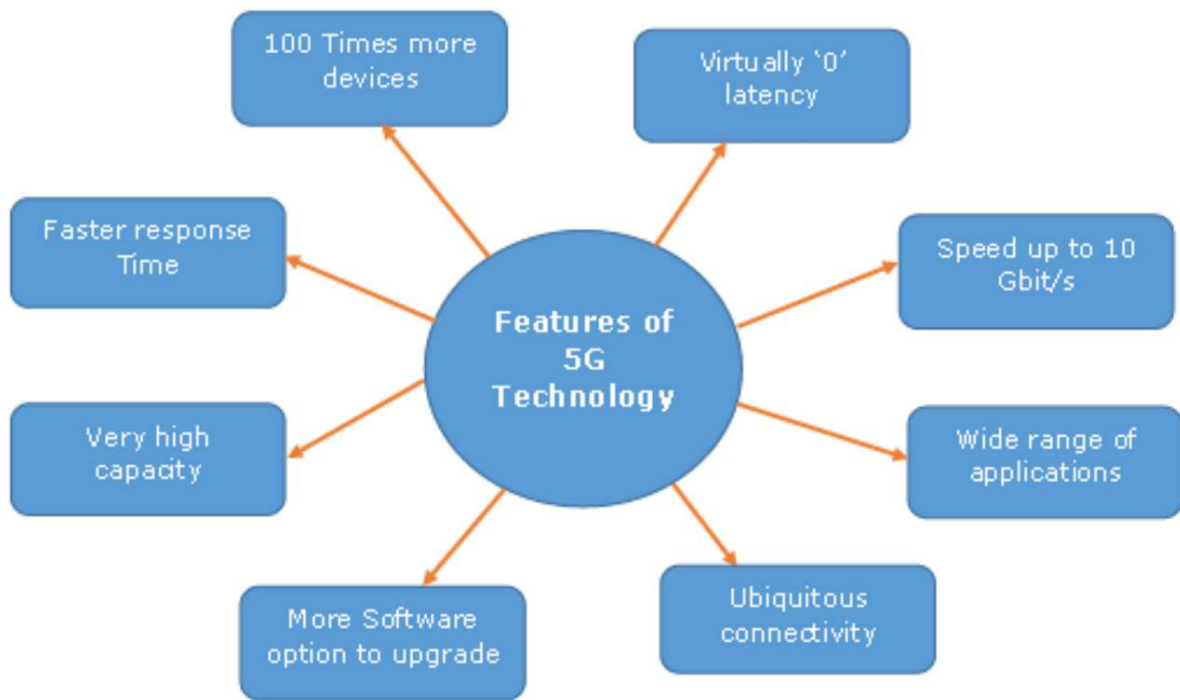
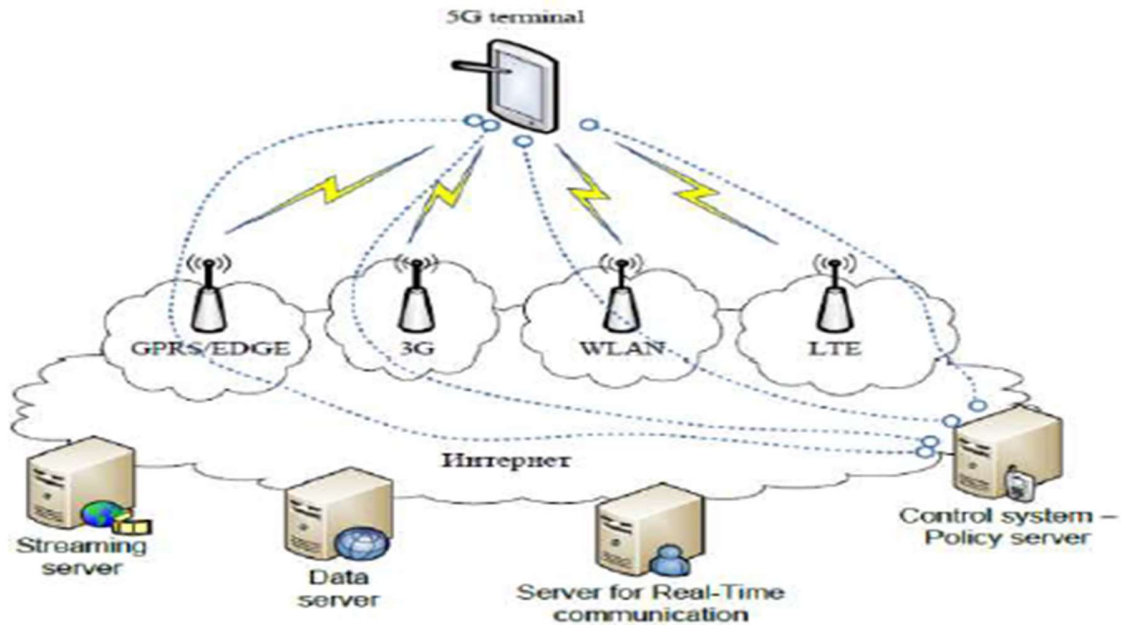

**Figure 4: Features of 5G technology.**

Architecture of 5G is highly advanced; its network elements and various terminals are characteristically upgraded to afford a new situation. Likewise, service providers can implement the advance technology to adopt the value-added services easily. However, upgrade-ability is based upon cognitive radio technology that includes various significant features such as ability of devices to identify their geographical location as well as weather, temperature, etc. Cognitive radio technology acts as a transceiver (beam) that perceptively can catch and respond radio signals in its operating environment. Further, it promptly distinguishes the changes in its environment and hence responds accordingly to provide uninterrupted quality service. [9]

## Chapter I: New generations mobile networks technology

The system model of 5G is entirely IP based model designed for the wireless and mobile networks (Figure 5).



**Figure 5: IP based 5G architecture.**

The system comprising of a main user terminal and then a number of independent and autonomous radio access technologies. Each of the radio technologies is considered as the IP link for the outside internet world. The IP technology is Moreover, to make accessible routing of packets should be fixed in accordance with the given policies of the user.

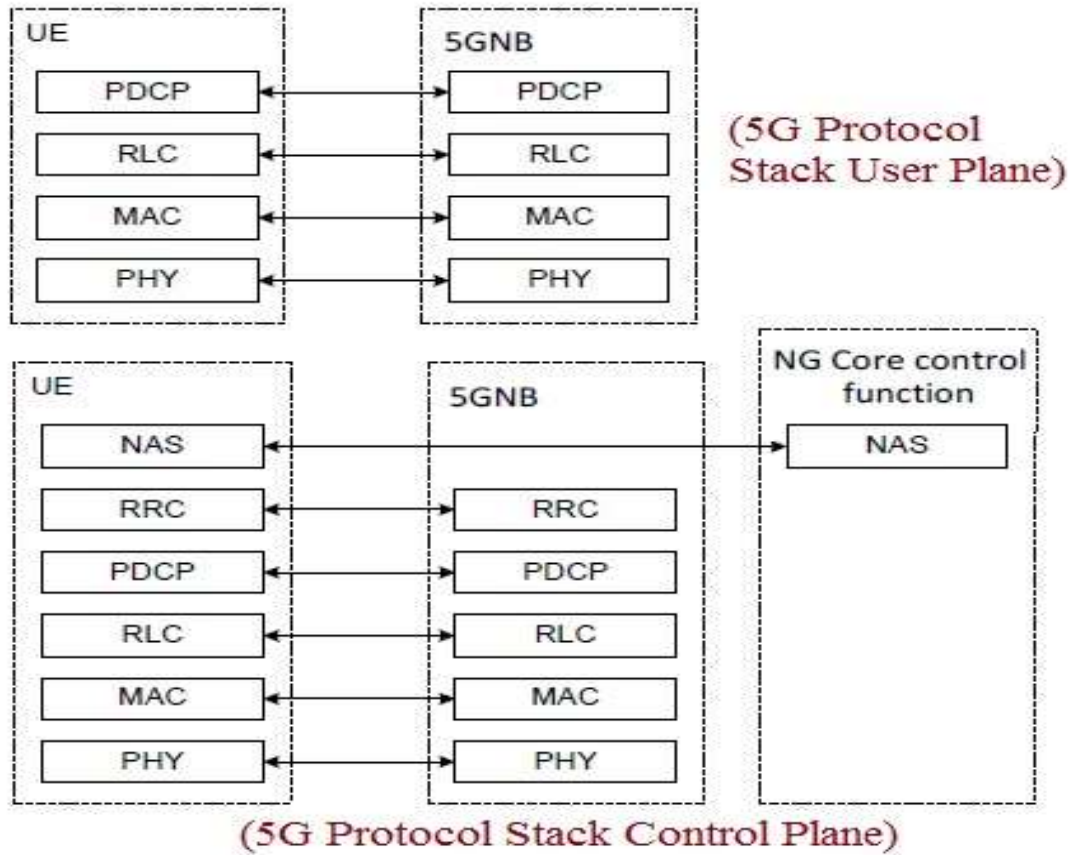

**Figure 6: Basic 5G layer.**

The 5G Master Core is convergence point for the other technologies, which have their own impact on existing wireless network. Interestingly, its design facilitates Master Core to get operated into parallel multimode including all IP network mode and 5G network mode. In this mode (as shown in the image given below), it controls all network technologies of RAN and Different Access Networks (DAT). Since, the technology is compatible and manages all the new deployments (based on 5G), it is more efficient, less complicated, and more powerful. Surprisingly, any service mode can be opened under 5G New Deployment Mode as World Combination Service Mode (WCSM). WCSM is a wonderful feature of this technology; for example, if a professor writes on the white board in a country – it can be displayed on another white board in any other part of the world besides conversation and video. Further, new services can be easily added through parallel multimode service.

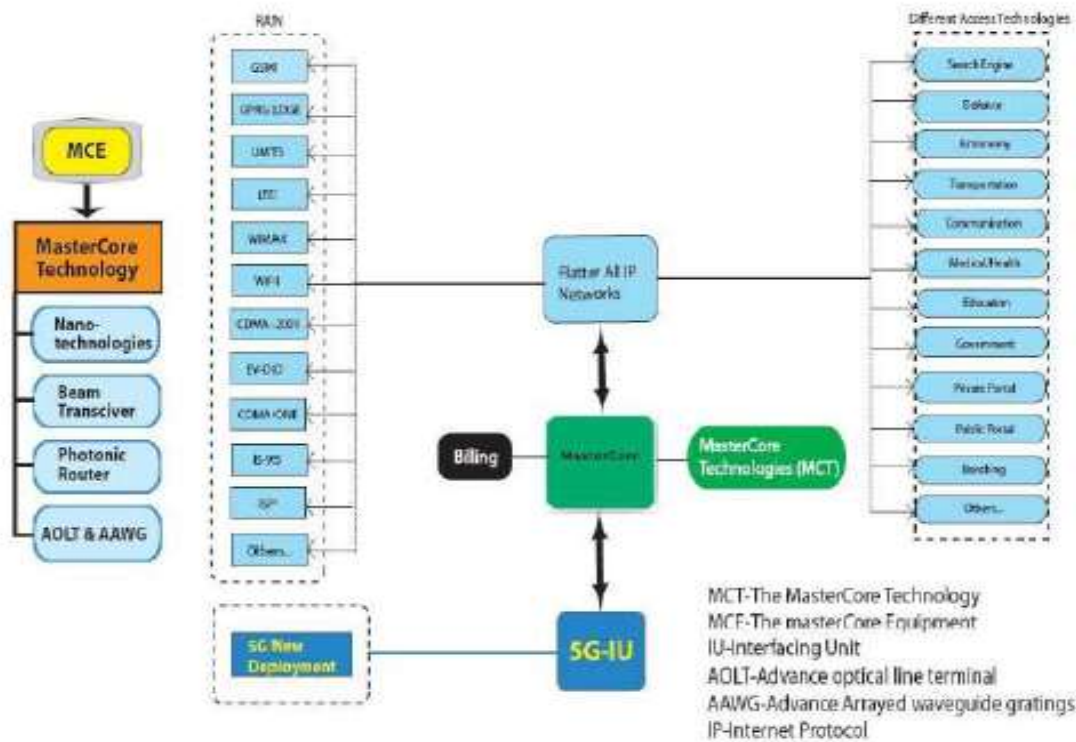

Figure 7: 5G master core.

#### 4- 6G Cellular Technology:

6G mobile network/Internet uses an air fiber technology with masts and transceivers on tall buildings and even lamp posts to create a local network capable of delivering phenomenal speeds instead of disappointing averages. The air fiber combination will be the best method to broadcast much secured information from transmitters to destinations. 6G's converged network provides local with a truly all-in-one solution: uploads, downloads, super-fast broadband Internet, multiple line telephones, CCTV monitoring, video conferencing every telecommunications requirement your business needs is catered for with 6G.

The 6th generation (6G) wireless mobile communication networks shall integrate satellites to get global coverage. The global coverage systems have been developed by four countries. The global position system (GPS) is developed by USA, the COMPASS system is developed by China, the Galileo system is developed by EU, and the GLONASS system is developed by Russia. Thus, these independent systems are difficulty for space roaming. The task of 7th generation (7G) wireless mobile communication networks is going to unite [10]

## Chapter I: New generations mobile networks technology

6G Internets use a combination of the latest in radio and fiber optics technology. They deliver through via line of sight (LOS). Which means they don't have to rely on the copper cable or base our speed on how to far your business is away from the exchange. 6G offer faster, more secure and cost-effective broadband network. This mobile system for the global coverage will integrate 5G wireless mobile system and satellite network. These satellite networks consist of telecommunication satellite network, earth imaging satellite network and navigation satellite network. The telecommunication satellite is used for voice, data, Internet, and video broadcasting; the earth imaging satellite network is for weather and environmental information collection, and the navigational satellite network is for Global Position System (GPS).

In 6G hand-off and roaming will be the big issue because those satellite systems are different networks and 6G has four different standards. Thus, the hand-off and roaming must take place between those four different networks but how it will occur is still a question.

In 6G the cost of mobile call will be relatively high but in 7G/7.5G/8G their problem will be reduced and lower level user will benefit from them. In 6G, the globe will be decorated by fly sensors with the help of 6G technology. These fly sensors will provide information to their remote observer stations; further these stations will check any activity upon a special area such as the activity of terrorists, intruders etc.

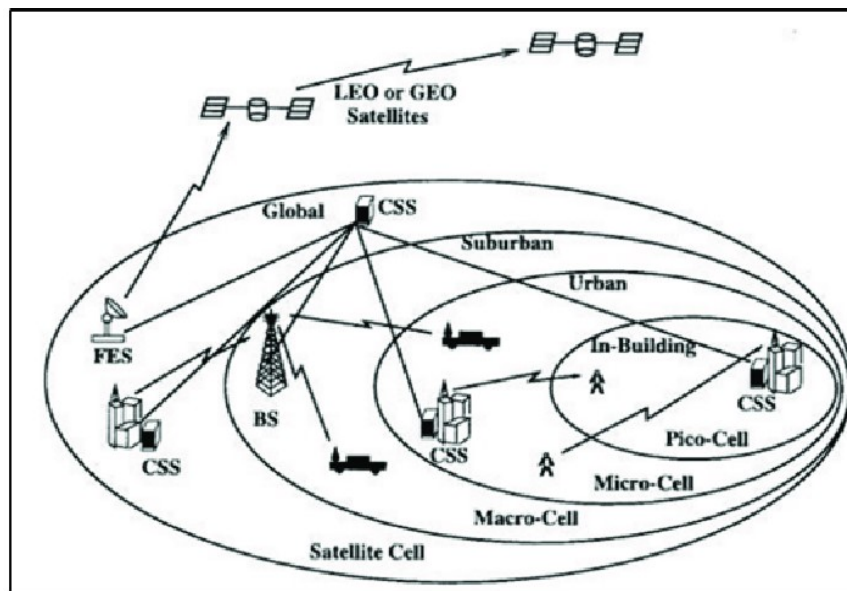

**Figure 8: 6G network architecture.**

**5- Comparison of different cellular technologies:**

Parameters	Cellular technologies		
	4G	5G	6G
<b>Service</b>	Wi-Fi, VoIP, LTE, WiMAX	WWW	Secured and global cellular services
<b>Frequency</b>			
<b>Multiplexing</b>	OFDMA	All with AI capabilities, MIMO, CDMA	CDMA
<b>Switching type</b>	Packet switching (All packet)	IPv6 but advancements are still to be done	All packet
<b>Core network</b>	Internet	Internet	Internet
<b>Data rate</b>	100-300 Mbps	About 100+Mbps	About 11 Gbps
<b>Pros</b>	Speed, high speed hand offs, MIMO tech, global tech	Better coverage area, low battery consumption, availability of multiple data transfer path, energy and spectral efficiency is more and has a high security	Global coverage system
<b>Cons</b>	Hard to implement, complicated hardware required	It is still under process and research on its viability is going on, it is difficult to achieve because of the incompetent technological support in most parts of the world, developing infrastructure needs high cost, security and privacy issue yet to be solved	Difficulty for space roaming, high cost of mobile call and similar with 5G disadvantages
<b>Location of first commercialization</b>	South Korea	Not yet	Not yet
<b>Time period</b>	Now	2020	Soon probably 2030
<b>Handof</b>	Horizontal and vertical	Horizontal and vertical	Horizontal and vertical

**Table 2: Components of haplotypic variation and paired FST value for the 38 complete genome sequences of SARS-COV-2 from South America.**

### **6- Conclusion:**

The world of mobile wireless communication is rapidly developing. The last few years have experienced a remarkable growth in wireless industry. Attempts are being made to reduce the number of technologies to a single global standard resulting in 5G, 6G and 7G. 5G aims a real wireless world with no limitations while 6G integrates 5G with satellite networks. Due to variable technologies and standards, with 6G handoff/roaming will be an issue. This drives the 7G of mobile wireless networks which aims to acquire space roaming. The world is trying to become completely wireless, demanding uninterrupted access to information anytime and anywhere with better quality, high speed, increased bandwidth and reduction in cost.

**Chapter II:**  
**Quality of service for different**  
**mobile networks**

## **Chapter II: Quality of service for different mobile networks**

### **1-QoS GSM (2G):**

In the area of telecommunications, the phrase Quality of Service (QoS) has a highly significant significance. This chapter's goal is to connect the project's theoretical framework to the assessment of service quality and performance, both of which are important terms in GSM technology. Indeed, the operator's ability to manage the network and carry out his activities and maintenance interventions depends on his ability to evaluate the status of the system and identify problems. In comparison to fixed networks, mobile networks offer a unique characteristic when it comes to assessing their performance. In the realm of mobile network communication, the phrase "quality of service" has a particular meaning. It has to do with the network's profitability and service dependability.

### **1-1-Definition:**

In ITU Recommendation E-800, quality of service is described as "an overall impact generated by the quality of operation of a service that affects the degree of satisfaction of a service's user."

Quality of service has become a determining factor for telecommunication operators in the current environment, and they have realized that the quality of their services and services must be constantly monitored and monitored on the one hand to know the state of operation of their infrastructure and on the other hand to improve their competitiveness.

The following principles are established to simplify and ease the understanding and execution of a basic quality of service strategy.

- Service quality refers to all qualities, characteristics, and factors that may be selected, measured, and compared to target values (threshold value).
- Some key quality features may be reduced as a result of service quality evaluation. Each property of the service devices does not need to be defined and measured.

The following are the performance metrics:

#### **1-1-1- Indicators of service quality:**

An indication is a value that is indicative of network performance and is based on one or more meters. The BSS quality of service indicators are designed to:

- Identify faults in radio subsystem components and implement remedial measures to control service quality.
- Detect and detect a cell's radio issues and assist radio optimization teams in analyzing the situation and defining remedial measures (frequency change, parameter modification, etc.);
- Changes in the radio subsystem should be monitored:
- Model of traffic
- Amount of traffic
- Network efficiency

## Chapter II: Quality of Service for different mobile networks

---

- Benefits of upgrading software versions
- Network behavior prediction based on traffic fluctuations.

The radio indicators are calculated using performance meters supplied by the OMC R radio subsystem's Operation and Maintenance Center. Different kinds of counters are grouped into three classes in the OMC R:

- Cumulative counters: each time the counted event occurs, the counter is increased. When a new period begins, it is reset. It simply shows the number of events that occurred over a certain period of time.
- Static Counters: These are static statistics gathered in relation to a particular resource's status.
- Observation events are details about a system occurrence. For example, for an SDCCH occurrence, the Channel seizure time is an observation counter that displays the time and date when the SDCCH is measured. [12]

### **Key performance indicators (KPIs):**

The Key Performance Indicator (KPI) is used to assess QoS in mobile networks (KPI). Key performance indicators (KPIs) are measurements that give information on a network's or process's performance. KPIs are calculated using formulas and a compilation of data. KPIs measure the duration of a call, the amount of traffic, and the overall quality of service throughout the network. During peak hours, KPIs are utilized to identify defective cells. For each KPI, a limit threshold is established, and if it is surpassed, an alert is sent to supervision, indicating the existence of a problem with the function that the KPI is monitoring.

### **1-2- challenges faced throughout the procedures:**

The several methods (instant assignment, regular assignment, handover, and directed retry) are almost identical in formalism. The difficulties involved in performing these operations are shown in the figureII.1 below. [13]

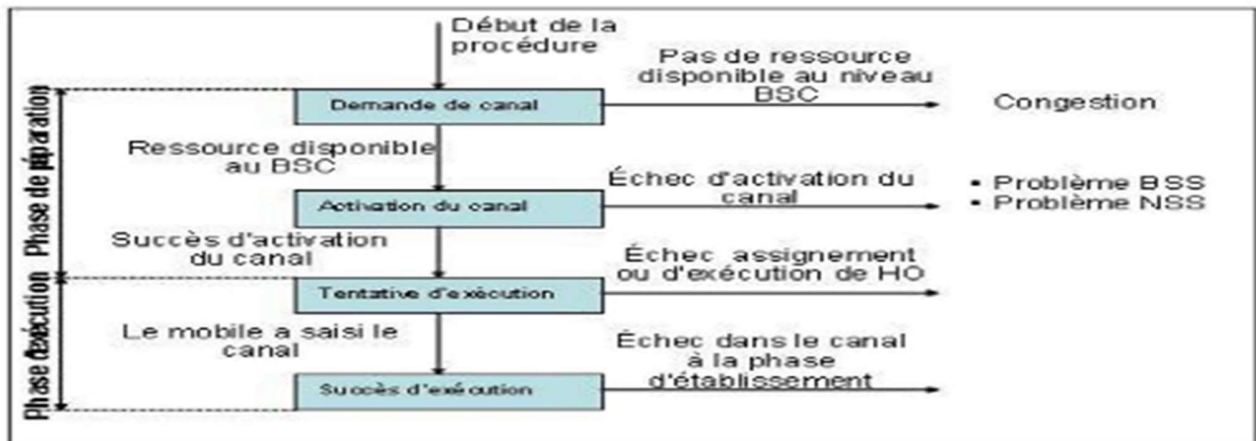

**Figure 9: Issues That arose throughout processes**

### 1-2-1- Issues with Call Outages:

On the subscriber side, these are the most problematic issues. The following are some of the many reasons of this issue:

- BSS cut-off: This kind of issue need the involvement of the WTO team to determine if the cuts are caused by a BSC hardware failure or a transcoding issue.
- Handover cut-off: if the handover attempt fails and the phone does not revert to its previous channel, the call is terminated.

Owing to an air interface issue: the call is terminated due to a radio failure. If most handovers are done on quality or level, the reasons may be inadequate cell coverage.

- One or more cell frequencies have been disrupted
- A issue with the cell aerial (antenna, feeder cables), particularly if the handover is done primarily at the field level of the connection amount.

### 1-2-2- Problems with handover:

Failures in outbound handovers may be attributed to the following factors: If the failure occurs during the preparation phase, the following factors may be to blame:

- Congested target cells
- In the event of an inter-BSC changeover, faulty connections on interfaces A;

The reason of a failure in the execution phase (handover failure on assigned channels) is a radio or BSS failure on the destination cell. In this scenario, the phone returns to its previous channel; the call is not terminated, but the handover is unsuccessful.

### **1-2-3- Issues with Appeal Call Establishment:**

Whether a cell fails to establish a call, a number of factors must be considered:

- If the region is adequately covered, assess if the cell is congested (TCH or SDCCH congestion);
- If the SDCCH channel break rate is large, the handover reasons are investigated;
- The TCH link failure rate is examined since there is no SDCCH decrease. A BSS failure (hardware failure) or a radio failure may be the culprits.

### **1-3-The measuring parameters are as follows:**

The primary components of the Drive-Test measurement chain are accessibility measurements (SDCCH) and communication establishment measures (TCH). These two measurements are in the standby state of the mobile and in the devoted state of the mobile. [13]

#### **1-3-1-Measures of network accessibility:**

It entails making actual phone calls and listening to the ringtone on the phone. The communication, however, is not stalled and therefore is not established. The proportion of calls that are successfully established is shown by the Call Setup Success Rate indicator. A call is defined as an application for the creation of communication that results in a call signal, a spoken message, or an occupancy tone. Any call must be established in no more than 10 seconds, according to the GSM standard. Furthermore, the blockage rate per loaded hour must be less than 2%. ( 2 percent ). Even if the call is established after 10 seconds, it is deemed a system performance failure. The following are some of the factors that may cause the Call Setup to deteriorate:

- Poor radio coverage
- Radio congestion

## Chapter II: Quality of Service for different mobile networks

- Equipment malfunction

At the SDCCH channel the existing operations are:

- SDCCH\_SEIZ\_ATT: SDCCH seizure attempts which indicates the number of attempts to SDCCH channel plug
- SDCCH\_BLOCK: SDCCH blocked: indicates SDCCH channel not allocated due to lack of resources
- SUC\_IMM\_ASS\_SDCCH\_cause successful SDCCH immediate assignment: successful assignment of a SDCCH channel (cause = answer to paging, emergency call, originating call, location update, etc.)
- SDCCH\_LOSS: this indicates the shutdown on the SDCCH channel

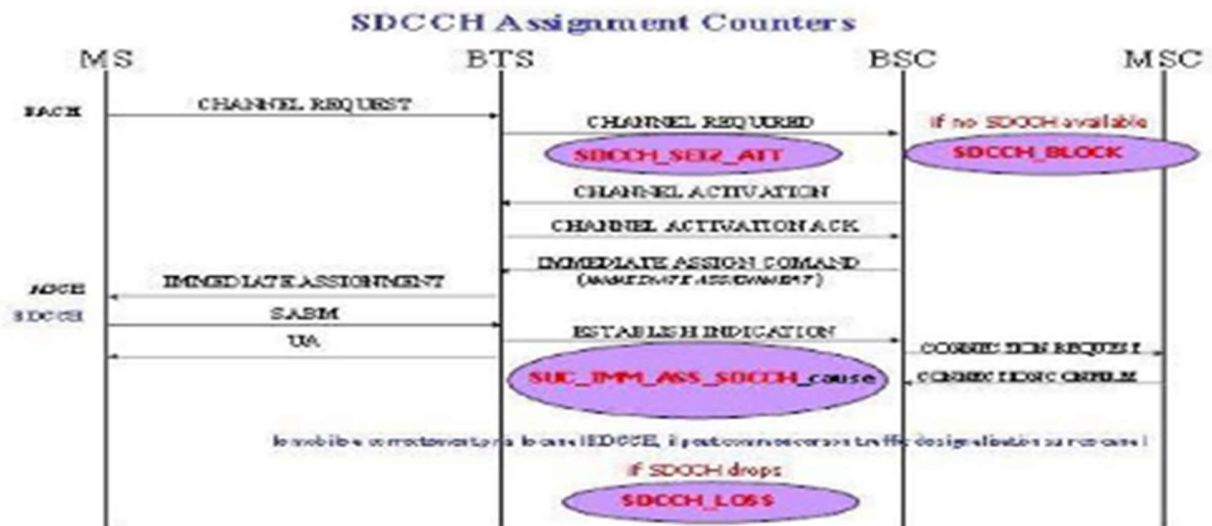

*Figure 10: SDCCH counter*

### 1-3-2- Measurements of field level (RXlev):

The beacon channel (BCCH) is measured, as well as the RxLev field number received by the mobile, which shows the number of bars indicating the strength of the received signal. The appearance of one or two bars on the terminal display or the indication of lack of the signal is caused by a low field level or the absence of the field. The network presence indicator, or RxLev, indicates the likelihood of initiating a communication at any location of coverage. These changes are occurring at the same time as the network accessibility improvements. There are two

## Chapter II: Quality of Service for different mobile networks

RxLevmeasuring units: the RxLev unit with a range of 0 to 63 and the RxLev unit with a range of 0 to 63. (dBm). The following is the connection between the two units of measurement:

The Table 3 below illustrates coverage by RxLev:

RxLev (dBm)	Niveau de couverture
-110 à -95	Pas de couverture
-95 à -85	Mauvaise couverture
-85 à -75	Assez bonne couverture
-75 à -65	Bonne couverture
-65 à -46	Très bonne couverture

*Figure 11: Network coverage by RxLev*

When the phone is in standby or "idle" mode, the RxLev is always measured. The following are the major factors that may influence the quality of radio coverage:

- insufficient number of BTS,
- poor physical and logical configuration of BTS (tilts, azimuths, power, etc.), antenna types and installation quality (losses in cables) or maintenance failure (feeder humidity, cable degradation, etc.),
- quality of the user's terminal (sensitivity) or deterioration of the RF transmit/receive part.

[13]

### 1-3-3-RXQual (Communication Quality Measure):

The RxQual value recorded by the mobile is evaluated in these measures. The audibility, sharpness, and clarity of a communication are referred to as voice quality. For the subscriber, this is a critical indication. The Bits Error Rate (BER) and Frames Erasure Rate (FER) in the operator are often used to identify it. The bad bit rate received on the total bits sent over the air interface is referred to as the BER. The user gets high quality communication if this rate remains below a particular level during the conversation. On the A-bis interface, the error frame rate relates to the concept of destructive collisions. When the interference level in more than three consecutive GSM bursts exceeds the permissible threshold, a destructive collision occurs. The GSM voice frame (sent in 8 consecutive bursts) would be badly received by the user in this scenario,

## Chapter II: Quality of Service for different mobile networks

lowering the quality of the speech signal. Frame losses can also result in microcoupures during the call causing poor communication quality.

Only in the dedicated state and on the server cell is the RxQual monitored; it is encoded in 3 bits and accepts readings from 0 to 7. The quality evaluation is shown in the Table II.2 below.

RxQual	Bit Error Rate (BER)	Communication quality
0	BER < 0.2%	Excellent
1	BER = [0.2% to 0.4%]	Good
2	BER = [0.4% to 0.8%]	
3	BER = [0.8% to 1.6%]	good enough
4	BER = [1.6% to 3.2%]	
5	BER = [3.2% to 6.4%]	Bad
6	BER = [6.4% to 12.8%]	
7	BER > 12.8%	Very Bad

*Figure 12: Correspondence between communication quality and BER the factors*

that degrade voice quality are:

- external interference level is too high (interference caused by emissions from non-network equipment),
- co-channel or neighboring channel interference is too high (bad frequency plane),
- insufficient radio coverage
- radio equipment that has been installed incorrectly,
- A issue with transmission (echo cancellations or poor synchronization resulting in loss of information, sizzling in voice communications and "white communications"),
- Inadequate handover setting.

### **1-4-The TEMS Investigation tool:**

TEMS Investigation is a fantastic tool for wireless network inspection, optimization, and maintenance. TEMS Investigation is a comprehensive solution for all the duties of a daily wireless network operator to improve the network, including data gathering, real-time analysis, and all-in-one post-processing. This approach removes the need for numerous tools, saving

## **Chapter II: Quality of Service for different mobile networks**

---

money as well as time and effort for operating personnel. GSM/GPRS, EDGE WCDMA, HSPA/HSPA+, LTE (including TD-LTE), CDMA, EVDO, WiMAX and TD-SCDMA, and other key technologies are supported.

This makes it an excellent choice for both new network gear and guaranteeing smooth network integration. Operators may enhance voice quality, accessibility, retention, and service performance by using TEMS surveys. TEMS surveys are critical throughout the network's lifetime due to a variety of strong and easy-to-use capabilities. The TEMS is used for: - Network configuration and optimization:

- Perform wireless network problem detection and diagnosis
- Using phone-based metrics to verify actual terminal behavior
- Examine cell coverage and capacity, as well as accessibility and security.

### 2- QoS 3G ( UMTS)

#### 2-1- Introduction

The UMTS network is a wireless mobile communications technology that may provide new multimedia services while also combining terrestrial and satellite communications. The UMTS network must meet various quality of service requirements for each service requested by the user due to the broad variety of applications it may serve. As a result, the notion of QoS was created at the UMTS network level, according to 3GPP standards. This chapter will cover a broad topic concerning QoS in UMTS networks, but first, let's look at what the UMTS network is all about.

#### 2-2- Definition of UMTS:

UMTS stands for Universal Mobile Telecommunications System. The Universal Mobile Telecommunications System (UMTS) is the successor of the Global System for Mobile Communications (GSM) network. It's evidence that mobile telecommunications has advanced to the third generation. Its goal is to satisfy the increasing demand for mobile phones and mobile Internet applications in a communications environment that is already overburdened. The WCDMA standard (Wideband Code Division Multiple Access), which is undoubtedly one of the most significant evolutions introduced to the 3rd generation of mobile networks, allows this network to transmit data at a speed of 2 Mbps. UMTS accepts a broad range of applications that may be used everywhere in the globe and provides the required connection to GSM technology and telecommunications standards.

#### 2-3- Architecture QoS global:

The first is architecture. Quality of service, in its broadest sense, is described as "all the phenomena that may affect service performance and determine the degree of user satisfaction with this service." Another meaning is that quality of service is the degree to which a service provided by a provider to a user complies with their agreement. For UMTS networks, QoS has been standardized. The primary goal of this standards is to allow UMTS to provide data transmission with suitable end-to-end QoS assurances. [14]

The architecture in layers of UMTS support services is shown on Figure 1. Each support service at a given level makes use of the services available at lower levels.

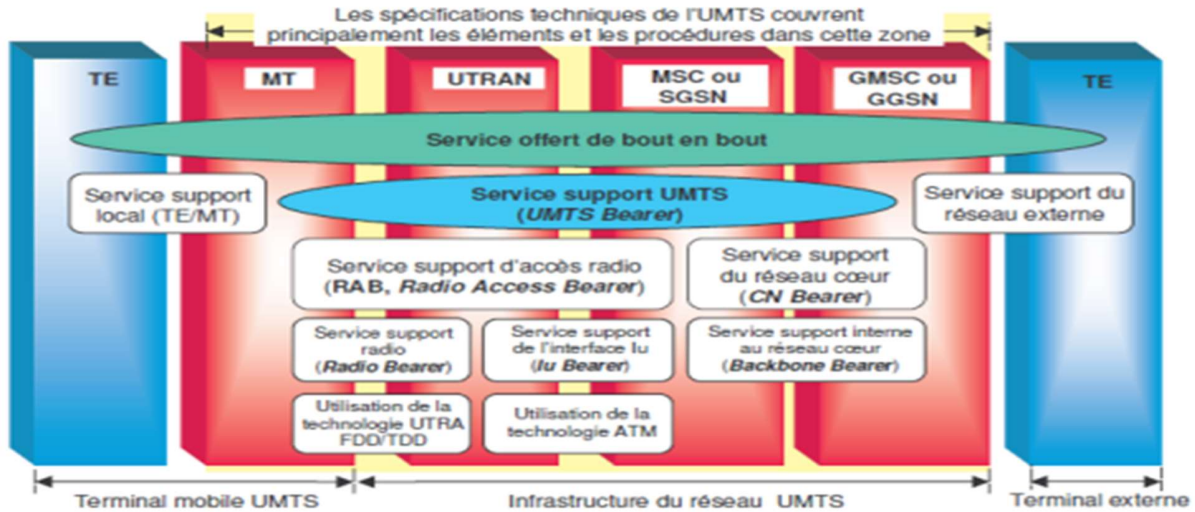

Figure 13: QoS architecture in the UMTS network

### 2-4- QoS classes in the UMTS network:

Four QoS classes have been defined by the 3GPP for the transport of multimedia applications in the UMTS network: the conversational class, the diffusion class, the interactive class and finally the background task class.

#### 2-4-1- The conversational class:

The best example of this class is telephony. It can also be used for new real-time, conversational Internet applications such as voice over IP. This class requires strict constraints on the transfer time of packets as well as on the variation of the transfer time.

#### 2-4-2- The dissemination class:

This class is used for one-way streams such as video or audio streaming applications. There are no strict constraints on the transfer time for streaming applications. On the other hand, the variation of the delay is an important parameter because it is perceptible by the user. However, this constraint on the time variation remains tolerant thanks to the receiver buffers which can cushion the time variations if they are still below a given limit.

### **2-4-3 The interactive class:**

This class is used for applications that need communication between the two ends. Web surfing is an example of this class's application. This is a transactional class. Because the user expects a response within a particular time limit, it necessitates some restriction on packet transmission time. Because they are "non-real-time" applications, this restriction is not stringent. On the other hand, since the applications carried by this class are very sensitive to losses, this class must have a low packet loss rate.

### **2-4-4- Background Task Class:**

In terms of transfer time, this is the least demanding class. This class transports applications whose users do not anticipate packages to arrive within a certain time frame. The loss rate is the most significant restriction. Packet loss has a high impact on this class. The background class includes apps such as email and SMS. The first two groups describe services that are time-sensitive. The latter two, on the other hand, are less dependent on the passage of time. [14]

## Chapter II: Quality of Service for different mobile networks

<b>Classes</b>	<b>Caractéristiques fondamentales</b>	<b>Délai</b>	<b>Exemples d'applications</b>	<b>Débit</b>	<b>Tolérant à l'erreur</b>
<b>Conversationnelle</b>	<b>Conserve la variation de temps entre les entités d'informations du flux de données conversationnelles</b>	<b>&lt;&lt; 1 s</b>	<b>Visiophonie</b>	<b>32-384 Kbps</b>	<b>Oui</b>
			<b>Jeux interactifs</b>	<b>1 Kbps</b>	<b>Non</b>
<b>Diffusion</b>	<b>Conserve la variation de temps entre les entités d'informations du flux de données</b>	<b>&lt; 10 s</b>	<b>Audio haute qualité</b>	<b>32-128 Kbps</b>	<b>Oui</b>
			<b>Images fixes</b>	<b>Non garanti</b>	<b>Non</b>
<b>Interactive</b>	<b>Modèle question/réponse Conserver le contenu du paquet (payload)</b>	<b>Environ 1 s</b>	<b>Commerce électronique</b>	<b>Non garanti</b>	<b>Non</b>
			<b>Navigation sur Internet</b>	<b>Non garanti</b>	<b>Non</b>
<b>Tâche de fond</b>	<b>La destination n'attend pas les données dans un certain temps Conserver le contenu du paquet</b>	<b>&gt;10 s</b>	<b>Fax</b>	<b>Non garanti</b>	<b>Oui</b>
			<b>Email (avec acquittement)</b>	<b>Non garanti</b>	<b>Non</b>

*Table 3: summarizes the QoS class characteristics of the UMTS network.:*

## 2-5- Quality-of-Service (QoS) management functions:

This paragraph describes the characteristics required to set up, change, and manage a UMTS support service with a particular QoS. Signaling and negotiation with external UMTS services are also goals of the latter. On the one hand, QoS management tasks may be done at the control plan level, and on the other hand, similar functions can be performed at the user plan level. [15]

### 2-5-1- QoS management functions in the control plan:

These functions are active during the set-up of the call or session for signaling. They are illustrated in Figure 2. where four QoS management functions are distinguished

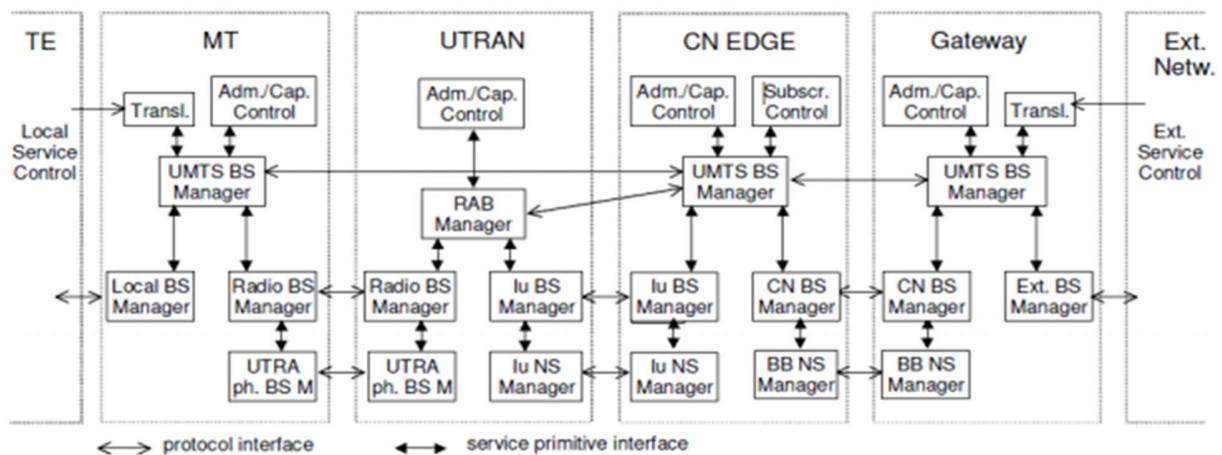

Figure 14: QoS management functions in the control plan

The translation functions, in the mobile terminal (MT) and the gateway, convert the signaling of the external service into internal primitives including the translation of the service attributes.

The intake or capacity control function looks after the resources related to the entities and decides whether new applications can be admitted.

## Chapter II: Quality of Service for different mobile networks

---

Bearer Service Manager in MT, CN EDGE (CN Enhanced Data Rate for GSM Evolution) and the gateway exchange signals between them and via the translation function with external instances to establish or modify an UMTS support service. Each of these managers questions its associated intake controller to verify the capacity of the network entity to support the requested service and the availability of the necessary resources. In addition, the CN EDGE manager checks with the subscription control function (contrôled'inscription) the administrative rights of the use of the service. The MT-level manager converts the attributes of the UMTS support service into attributes for the local support service. 26 The CN EDGE level manager converts the attributes of the UMTS support service into the attributes of the RAB and Iu services and the attributes of the CN support service. It also requests the support services of its manager Iu, its manager of CN and the manager RAB in UTRAN to provide the requested service. The RAB manager verifies through its intake control whether UTRAN is able to support the requested service and whether the necessary resources are available. It converts the attributes of the RAB service into attributes of the radio support service and attributes of the support service Iu and asks the managers of the radio support service and Iu to provide the support services with the requested attributes. At the gateway level, the UMTS Support Manager converts the attributes of the UMTS Support Service into attributes of the CN Support Service and uses the CN Support Service to provide the UMTS Support Service. It also converts UMTS support service attributes into external support service attributes.

### **2-5-2- QoS management functions in the user plan:**

These functions are active for the transmission of user data throughout the call or session. They are shown in Figure 2, which distinguishes four QoS management functions.

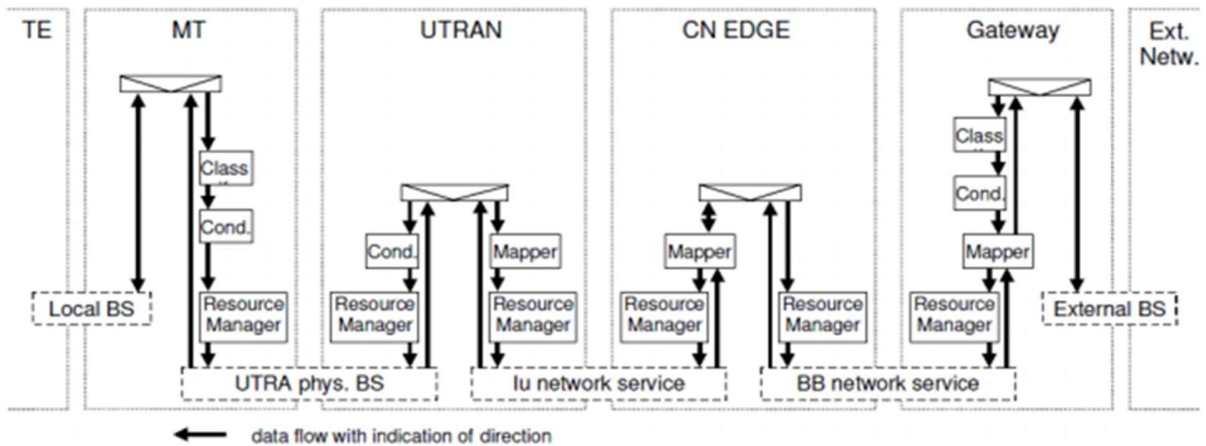

Figure 15: QoS Management Functions in the User Plan

The classification function (function classification) at the bridge and MT level assigns the user data units, received from the external or local support service, to the appropriate UMTS 27 support service according to the need of each user data unit in quality of service. The appropriate UMTS support service comes from the header of the data unit or data traffic characteristics.

The traffic conditioner (traffic conditioner) at the mobile terminal allows the upward user data traffic to comply with the QoS attributes of the appropriate UMTS support service. At the gateway level, the traffic conditioner provides the down-traffic compliance with the QoS attributes of the appropriate support service. Packet-oriented transport of data units in the descending direction from the external support service to UTRAN and buffering in UTRAN may result in bursts of data units not conforming to the QoS attributes of the UMTS support service. A traffic conditioner in UTRAN adapts this downflow of data units according to the appropriate QoS attributes.

The mapping function marks each data unit by indicating the specific QoS of the support service responsible for transferring the data units. The purpose of this function is to have the expected QoS at each network node. Each resource manager of a network entity is responsible for managing a specific resource. The Resource Manager distributes its resources among all support services requesting the transfer of data units on these resources, i.e., it tries to provide the requested QoS attributes for each individual support service. Resources management means include scheduling, bandwidth management and power control for radio support

### 2-6- QoS characteristics:

The layered design necessitates the creation of QoS attributes for each of the media services previously described. These characteristics are used to convert end-to-end QoS requirements into needs specific to each data connection support service. These characteristics are shown in Table 1.02, along with their relevance to the various traffic classes, which are also QoS attributes.

- Maximum bit rate: this is the maximum amount of data that the user or program may accept or send. Depending on the network capabilities, all aspects of the UMTS support service may be completed with maximum throughput traffic.
- Guaranteed throughput: divided by the time, this is the number of guaranteed bits provided by UMTS in a SAP. It specifies the throughput that a user or application may expect from the UMTS support service. This parameter also simplifies admission management and resource allocation in UMTS depending on their availability.
- The SDU sequence delivery order: This parameter determines whether out-of-sequence SDUs are accepted, lost, or reordered according to the parameters.
- SDU maximum size: this is the maximum size for which the network meets the agreed QoS. This variable is used to regulate and monitor intake.
- SDU error rate: this is the percentage of SDU that is lost or improperly detected. It was first used with RAN to setup protocols, algorithms, and error detection methods.

The error rate of undiscovered bits in the issued SDU is shown by the residual binary error rate. This property will show the binary error rate in the issued SDU if there is no error detection request. It may also be used to set up radio interface techniques and protocols, as well as identify coding mistakes.

- Erroneous SDU Delivery: This option determines whether an erroneous SDU should be provided or abandoned.
- The transfer delay (ms): This parameter specifies the maximum delay to provide 95 percent of all SDU supplied during the lifespan of a support service, where an SDU time frame is specified from the moment of the SDU transfer request to a SAP until it is transferred to another SAP.
- Traffic processing priority: this defines how important it is to handle all SDU of one UMTS support service vs SDU of another. With the interactive class, we must distinguish between

the characteristics of the support service that UMTS uses to arrange traffic in a sequential manner.

- Allocation/retention priority: this defines the relative significance of a UMTS support service's allocation/maintenance to the others.

Attributes for Radio Access Media Services (RAB) must be applied to both the CS and PS domains. This list of characteristics is quite similar to the preceding list, which included the attribute. This feature describes the properties of the SDU source that was supplied. It is only relevant to courses that are conversational or streamed. It enables UTRAN to compute and apply a statistical multiplexing gain on radio interfaces for admission control. [16]

### **2-6-1- Attributes of real-time services:**

Although the source throughput for real-time services (conversational class and streaming) may fluctuate, the traffic classes are considered constant throughput (non-sbursty). The maximum bitrate with which the UMTS Support Service (UMTS Bearer Service) may provide the Service Data Unit (SDU) at the Service Access Point (SAP) level can therefore be specified using a maximum bitrate. The guaranteed throughput, which may be considered as an important element of 20 QoS for resource allocation, is not required for UMTS media. Guaranteed throughput determines the minimum resource required.

Since the flow rate is constant, it is important to guarantee a transfer time for an arbitrary SDU. The supports of the conversational classes and streaming are probably realized in the RAN without retransmission on the radio link. So the transport on the RAN will be more efficient if the size of the RLC-PDU is adapted to the size of the SDU of the UMTS media. For this reason, the insertion of information on the size of the SDU is necessary. This motivates the use of information on the SDU format

### **2-6-2- Best Effort Service Attributes:**

Best effort services consist mainly of interactive and background classes of traffic. Interactive classes are optimized for transporting interactions between a human being or a machine with remote equipment (web browsing for example). The characteristics of the traffic source are unknown but can be considered variable flow. The Background class is optimized for machine-to-machine communication that is not time sensitive (messaging services for example).

Background applications tolerate a higher delay than interactive applications; this is in fact the main difference between these two classes.

The traffic throughput generated by these two classes of traffic is variable (bursty), it can increase to use all available bandwidth. In order to limit the data throughput delivered to applications and external networks, the introduction of the maximum bit rate parameter is required.

The data integrity parameter is needed for specifying acceptable error profiles. The SDU loss rate, residual binary error rate, and number of erroneous SDU are used to define the application's error rate needs. It is critical to distinguish between the characteristics of the supports in the interactive class. Another option would be to put in place absolute assurances on the latency, bit rate, and other parameters, which seems to be difficult to achieve in the RAN/CN at the moment. A traffic handling priority is utilized instead. [16]

### **Conclusion:**

In this part, we have studied the modelling of UMTS networks and QoS with its performance parameters trying to specify the possible context application of each model studied. Measurable QoS parameters in networks UMTS is also described in detail. These parameters should be optimized or at best improve to satisfy network subscribers in terms of QoS. In order to evaluate and improve these QoS parameters.

### **3- QOS 4G LTE:**

The quality of service in the LTE/EPC network technically translates into systems and mechanisms to offer each type of service its own requirements so that the end-user is satisfied with the use of these services. These mechanisms integrate different processes and concepts that will be the focus of this chapter. When the EU registers it on the LTE network, it immediately provides the EU with IP connectivity to the selected NDS. The EU can thus use this connectivity by default to transmit and receive data. However, in order to establish a call with a specific quality of service (for example, a VoIP call), the EU must initiate a supplementary procedure. We will first present in this chapter the notions of bearer and bearer EPS, already mentioned in the previous chapter. The concepts of default EPS bearer and dedicated EPS bearer, specific to

LTE, will also be presented in order to identify their particularities. Finally, we will describe the parameters and the QoS management policy standardized by 3GPP in version 10 of the LTE network.

### **3-1- The concept of bearer:**

In any network, processing resources within nodes are limited and shared among users. Depending on the nature and technology of the network, increasing these resources by the operator can be complex and costly. In a mobile network, for example, the radio resource (spectrum) is particularly expensive. This concern led to consideration of mechanisms optimising the use of these resources on the radio interface, but also on the other network interfaces involved in the EU – network user plan. These Quality of Service mechanisms (or QoS for Quality of Service) aim to provide the user with the requested service with a satisfactory quality, while minimizing the resources used to achieve it.

The importance of such mechanisms is illustrated in the following Figure 3.01. In this example, EU2 has an active voice call with a fairly stable throughput. EU1 is browsing the Internet and starting a download. In the absence of an appropriate resource-sharing mechanism, the EU1 would then monopolize the system's bandwidth, depriving the EU2 of 43 resources to receive data. On the other hand, by allowing a maximum instantaneous throughput in the EU1 and guaranteeing a minimum throughput in the EU2 for its voice call, the EU1 traffic will be smoothed, while the EU2 will be able to receive data at the rate at which it is produced, without the EU1 flow changes.

1. Sans mécanismes de QoS, l'UE2 subit les variations de trafic de l'UE1

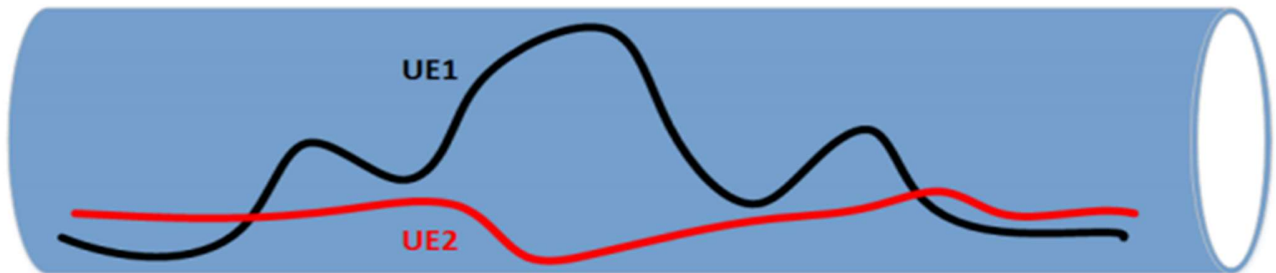

2. Avec des mécanismes de QoS: l'UE2 peut avoir un débit garanti, l'UE1 ne peut monopoliser toute la bande passante

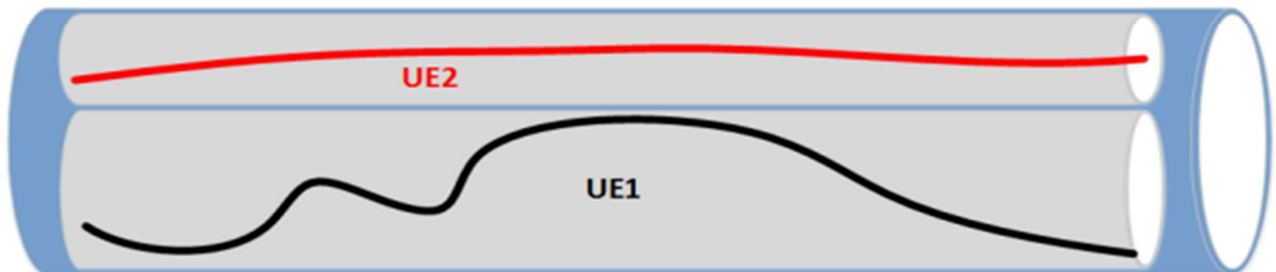

*Figure 16: Need for QoS mechanisms when accessing shared resources*

In order to allocate resources effectively to the needs of a call, the concept of bearer was introduced in Telecommunications, from the design of the GSM system. A bearer can be seen as a pipe between two network entities that communicate with each other on an interface, a pipe whose certain characteristics are negotiated between these entities during its establishment and which allows data transfer. The concept of bearer is thus applied to network interfaces whose resources must be saved, and in particular to:

- The radio interface, between the EU and the **eNodeB**;
- The S1 interface between E-UTRAN and the core network;
- The interfaces of the core network.

The bearers of these interfaces form an aggregated bearer, between the EU and the core network: the EPS bearer (or EPS bearer). [17]

### 3-1-1- The EPS Bearer:

Connectivity to a data network via E-UTRAN and EPC is provided by an EPS bearer. It carries traffic flows that must receive the same QoS processing between the UE and the PGW.

- The radio bearer on the Uu interface, between the UE and eNodeB;
- The S1 bearer, between eNodeB and S-GW (S1-U interface);
- The S5/S8 bearer, between S-GW and P-GW.

The radio bearer and the S1 bearer also form a logical connection between the UE and S-GW: the ERAB (for E-UTRAN Radio Access Bearer), which is an aggregated element of the EPS bearer. The ERAB is completely comparable in principle to the RAB defined in UMTS between the UE and the SGSN (Serving GPRS Support Node). Finally, the combination of the EPS bearer and the external data network bearer provides end-to-end support for the service. [18]

These elements and the network entities that support them are shown in the following figure.

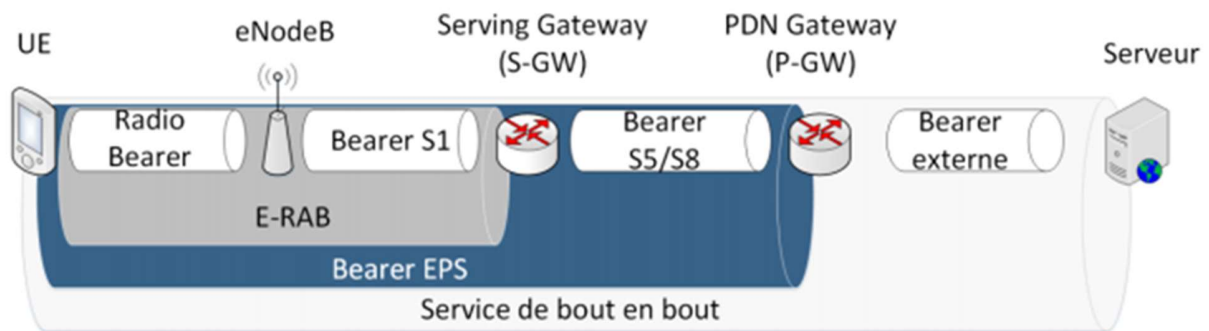

**Figure 17: The EPS Bearer in the LTE/EPC System**

In addition, an EPS bearer is characterized by protocol parameters, which allow the end-to-end routing of the data transmitted on this bearer, but also by Quality of Service parameters.

A data bearer carries the data packets of an EPS bearer between the UE and eNodeB. For an established EPS bearer, there is only one data bearer, sometimes referred to as the abbreviated DRB, for Data Radio Bearer, as opposed to signaling bearers (SRB) for Signaling Radio Bearer, also used on the radio interface but for the transport of RRC and NAS messages. A DRB is established by the RRC Connection Reconfiguration procedure.

The radio bearer consists of the following elements:

- A logical channel of DTCH (Dedicated Traffic CHannel) data for a DRB, or a logical channel of DCCH (Dedicated Control CHannel) signalling for a SRB--
- A PDCP configuration, for header compression (for a DRB), data unit protection (for a DRB or a SRB) and data management during handover (for a DRB)
- A RLC configuration, for the setting of acknowledgements in RLC-AM mode in particular
- A MAC configuration, which includes the group to which the radio bearer belongs for the Buffer Status Report.

These configuration parameters are determined by the eNodeB based on the capabilities of the terminal and the characteristics of the EPS bearer communicated by the MME. Finally, the establishment of an EPS bearer necessarily implies the creation of an EPS bearer context within the MME, P-GW, S-GW and the EU. This context associated with the EPS bearer remains active in this equipment when the radio interface and S1 bearers are released without explicitly disabling the EPS bearer context. The GTP tunnel terminations on the S-GW and P-GW are maintained in this case, with the EPS context. This EPS bearer context is similar to the PDP (Packet Data Protocol) context used in GPRS and UMTS, which may persist while the Radio Access Bearer (RAB) is released.

When establishing a secure logical connection between the EU and the MME, a radio context is created within the EU eNodeB, at the initiative of the MME. This context contains data on active EU bearers (notably DRB), the RRC connection, EU mobility and AS security established with the EU. It is transmitted to the target eNodeB during an LTE handover. It is not a context to bear EPS. [18]

### **3-2- The QoS parameters:**

A bearer is described by a set of parameters that apply to the interface as well as the equipment that manages it. They can be grouped into two categories: transport parameters (IP address, endpoint, etc.) and QoS parameters (latency, throughput, error rate).

Some applications require network-guaranteed throughput, such as a video streaming session or a voice call. The associated EPS bearer must then guarantee this flow. There is 52 reference to a GBR (Guaranteed Bit Rate) bearer, when resources are persistently allocated

## Chapter II: Quality of Service for different mobile networks

---

within the network for that bearer, or to a non-GBR bearer otherwise. A default bearer is always a non-GBR bearer, while a dedicated bearer can be GBR or non-GBR. The QoS of the EPS bearer is characterized by parameters that we will present in detail in the following sections:

- The class (or label), called QoS Class Identifier (QCI)
- Allocation and Retention Priority (ARP)
- Guaranteed Bit Rate (GBR), if applicable
- Maximum Bit Rate (MBR)

In addition, the network informs the UE of maximum aggregated flows on several EPS bearers: these are the APN-AMBR (Access Point Name-Aggregated Maximum Bit Rate) and UEAMBR (User Equipment- Aggregated Maximum Bit Rate) parameters described in the following. These parameters are therefore common to a set of EPS bearers. [19]

### 3-2-1- The QoS Class Identifier (QCI):

The QCI is a defined parameter within the LTE/EPC system to differentiate Service Qualities between different service streams. The UE and network nodes such as eNodeB, SGW, P-GW determine the processing to be applied to the data packets of an EPS bearer according to the QCI value defined for that bearer. Nine QCI are identified in the 3GPP standard, each defined by the following characteristics:

- Type of resource (GBR/non-GBR)
- The priority
- Transmission time within the LTE system
- The residual error rate.

The objective of these standardized QCI is to ensure that services receive the same level of end-to-end QoS in an environment involving multiple infrastructure builders. For example, the treatment applied by an eNodeB must be consistent with that applied by S-GW and P-GW, otherwise the quality constraints related to the service may not be respected.

-The following table describes the characteristics of standardized QCI. [20]

## Chapter II: Quality of Service for different mobile networks

QCI	Type de ressource	Priorité	Délai de transmission	Taux d'erreur résiduel	Exemples d'utilisation
1	<b>GBR</b>	2	100 ms	$10^{-2}$	Voix
2		4	150 ms	$10^{-3}$	IPTV, Streaming vidéo
3		3	50 ms	$10^{-3}$	Jeu interactif
4		5	300 ms	$10^{-6}$	Vidéo à la demande
5	<b>N-GBR</b>	1	100 ms	$10^{-6}$	Signalisation IMS (IP Multimedia Subsystem)
6		6	300 ms	$10^{-6}$	Vidéo à la demande, services basés sur TCP (navigation web, courriel, chat, FTP, transfert de fichier, peerto-peer...)
7		7	100 ms	$10^{-3}$	Voix, streaming video, jeu interactif
8		8	300 ms	$10^{-6}$	Bearer EPS par défaut pour les abonnés premium ou privilégiés
9		9	300 ms	$10^{-6}$	Bearer EPS par défaut pour des abonnés non premium

*Table 4: QCI Parameter Mapping Table*

These characteristics are not transmitted explicitly in the signalling between the equipment; only the QCI values are. If the previous Standard QCI table is used in the operator's network, the equipment will match the same QCI with QoS characteristics. These QICs are, however, indicative and the operator can use other QICs, or associate other values with QIC 1 to 9 and thus define its own QCI table, configured within the equipment that will process the data flows (eNodeB, S-GW, P-GW).

The priority given in this table refers to the processing priority within the equipment associated with the QCI.

The Packet Delay Budget (PDB) parameter defines the time limit for data transmission between the EU and P-GW. For a given QCI, the PDB value applies

## Chapter II: Quality of Service for different mobile networks

---

in the ascending and descending directions. The PDB is thus intended to assist nodes transmitting data from the user plane in their scheduling and configuration functions of the data link layers (level 2 of the OSI model). Within the eNodeB for example, the PDB can be taken into account as part of the data scheduling function on the radio interface and the setting of the RLC and MAC layers (maximum number of HARQ - Hybrid Automatic Repeat reQuest - and RLC retransmissions allowed, configuration of RLC retransmissions, PBR or Prioritized Bit Rate).

The PDB is a flexible limit value: if the delay of some data packets exceeds the PDB, they are not necessarily deleted. However, it is expected that most data units will be issued with a time far shorter than this threshold. The PDB should be interpreted as “98% of the data units are transmitted with a delay less than or equal to the value of the PDB”. In some cases of congestion, however, this may not be achieved. The essential contribution to the PDB comes from the radio interface, while the transit over the operator’s network (between eNodeB and P-GW) is about ten milliseconds. However, this delay between eNodeB and P-GW may vary depending on the EU situation and the operator’s strategy: in the case of international roaming for example, and if the originating operator chooses to pass the data through its network, traffic to the EU will therefore pass through the PGW of the originating network before reaching the visited network or VPLMN (Visited Public Land Mobile Network). For example, the delay between P-GW and eNodeB may exceed 50 ms for intercontinental roaming and therefore does not include the transmission delay on the radio interface. We understand that some services such as interactive games can be difficult to provide in this type of scenario.

The Residual Error Rate or Packet Error Loss Rate (PELR) parameter refers to the error rate on the transmission of Level 2 data units, for example the rate of IP packets processed within the network that could not be delivered to the EU PDCP layer. For a given QCI, the value of the LRSP applies in the up and down directions, . It should be noted that this objective of reliability in data transmission is not necessarily achieved in the event of congestion. The purpose of the LRSP is to allow an appropriate configuration of the data link layers (for example RLC and MAC in E-UTRAN). The error rate between eNodeB and P-GW is considered negligible (excluding congestion cases), so the LRSP applies mainly to the radio interface between EU and eNodeB.

### **Conclusion:**

This chapter covered the basics of LTE network quality of service in its release 10. The notions of EPS bearer and QoS parameters are at the heart of the differentiated service processing mechanism. Added to this is the processing and management of policy and rules in the data network to achieve a satisfactory quality of service to users. Quality of service management, however, involves more than a simple notion.

In this part, we have studied the modelling of UMTS, LTE, GSM, networks and QoS with its performance parameters trying to specify the possible context application of each model studied. Measurable QoS parameters in this networks is also described in detail. These parameters should be optimized or at best improve to satisfy network subscribers in terms of QoS. In order to evaluate and improve these QoS parameters.

**Chapter III:**  
**5G Quality Of Service**

### Chapter III: 5G quality of service

#### 1- 5G QoS:

Quality of service (QoS) refers to the measurement of the overall performance of a service experienced by the users of the network. To quantitatively measure the QoS packet loss, bit rate, throughput, transmission delay, availability, jitter, etc. related aspects of service are considered. Following figure show the performance of channel Bandwidth (BW) with and without QoS.

5G Quality of Service (QoS) model is based on QoS Flows. Each QoS flow has a unique identifier called QoS Flow Identifier (QFI). There are two types of flows: Guaranteed Bit Rate (GBR) QoS Flows and Non-GBR QoS Flows. The QoS Flow is the finest granularity of QoS differentiation in the PDU Session. User Plane (UP) traffic with the same QFI receive the same forwarding treatment.

**2-5G Network's function:**

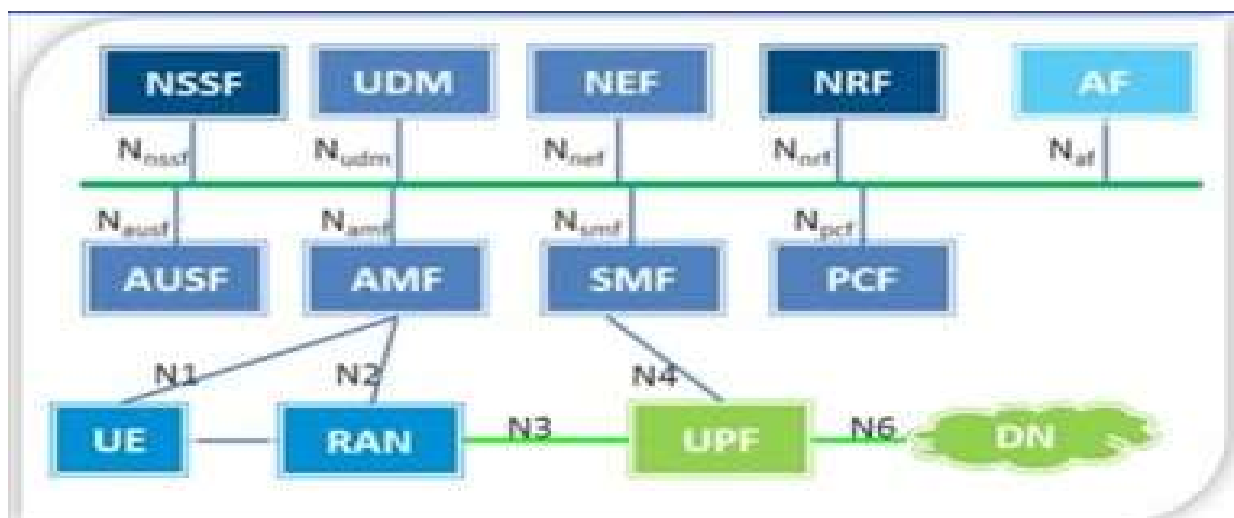

*Figure 18:5G network architecture*

This diagram is a service based architecture of 5G network (control plane , user plane).control plane network function are connected on a common bus and they interact with each other on API , so that why you recorded service based architecture, and all this notes actually not notes but is software process so that means this network function can be deployed on any data center, into the lord side we have elements which are called UPF(user plane function) because all the user traffic will passe into the user plane , the traffic is not required to go to the core and come back ,user plane traffic will passe ( user equipment then radio network access then user plane function the data network

**2-1-AMF (Access and Mobility Management Function):**

it is a control plane function in 5G core network the main function and responsibilities of access mobility function are When we say mobility management the AMF actually knows the location of user equipment, if the user equipment active the AMF will know the cell ID where that equipment is located, if the user equipment not connected and Idle, so at least it will know the tracking area where user equipment isn't present, the tracking area is a cluster of cells of gNB

-registration management

-reachability management

-connection management

-mobility management

### **2-1-1-registration management:**

Allows a UE to register and de-register with the 5G system. a UE must complete the registration procedure to receive authorization to use 5G services.

Registration moves the UE from RM-Deregistered state to the RM-Registered state. registration creates a UE context within the network.

### **2-1-2-reachability management:**

Ensures that a UE is always reachable, it is possible to page the UE when there is a requirement to establish a mobile terminated connection. Paging a UE which is in the CM-IDLE (connection management) state triggers the UE to initiate the NAS Service request procedure and subsequently establish an N1 signaling connection before moving into the CM-Connected state.

**/N1:** The N1 interface is a transparent interface from User Equipment (UE) to the AMF. It is used to transfer UE information (related to connection, mobility and sessions) to the AMF. In this respect, it is similar to the NAS in 4G, which conveyed information from the UE to the core network, rather than the Access Stratum, which is used exclusively in the radio network, from the UE to the radio access point.

### **2-1-3-CONNECTION MANAGEMENT:**

Establishes and release the control plane signaling connections between the user equipment and AMF, N1 signaling connection moves the user equipment from CM-Idle to CM-connected

### **2-1-4-Mobility Management:**

Is used to maintain knowledge of UE location within the network. the UE is required to complete periodic registration updates after it has completed initial registration. these periodic updates act as keep-alive to verify that UE remains on the system, and has not moved out of coverage or become unavailable due to any other reason (for example UE stopped working, battery died). UE is also required to complete updates due to mobility. these updates are

triggered if UE moves outside the current registration area (outside of tracking area or list of tracking areas within the UE is currently registered)

### 2-2-SMF (session management function):

The 5G Session Management Function (SMF) is a fundamental element of the 5G Service-Based Architecture (SBA). The SMF is primarily responsible for interacting with the decoupled data plane, creating updating and removing Protocol Data Unit (PDU) sessions and managing session context with the User Plane Function (UPF).

The main responsibilities of SMF are as follows:

- PDU Session Management
- IP Address Allocation
- GTP-U Tunnel Management
- Downlink Notification Management

#### 2-2-1-PDU Session Management :

Includes setup, modification and release of PDU sessions. For ease of understanding a *PDU session* is equivalent to the concept of EPS Bearer in 4G. It is logical connection between UE and the exit of User Plane Function (UPF) towards a specific Data Network (External network, or Internet)

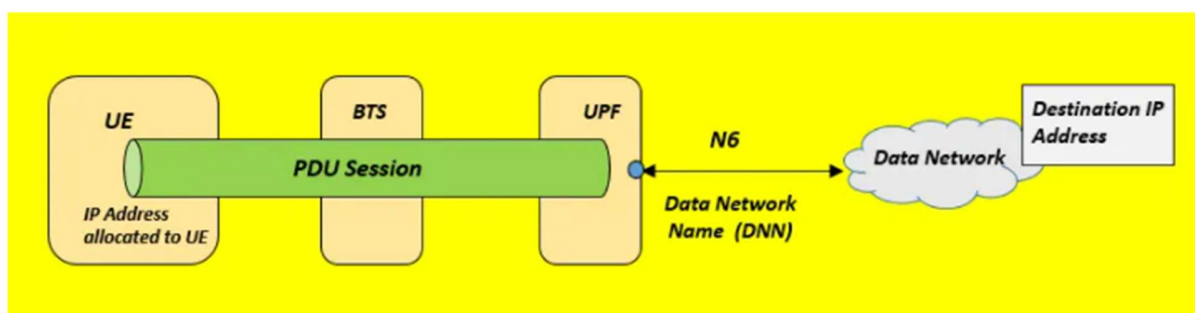

*Figure 19: PDU Session Illustration*

- PDU Session management requires SMF to complete signaling towards the UE, Base Station and User Plane Function (UPF).
- SMF can signal directly with the UPF but requires the AMF to support signaling towards the UE and Base Station
- SMF uses Non Access Stratum (NAS) signaling messages to communicate with the UE. Both the base station and AMF act as transparent routers for these messages which are relayed between the SMF and UE.
- UE can initiate the setup of a PDU Session send a *NAS: PDU Session Establishment Request*. Assuming a successful setup, SMF responds with a *NAS: PDU Session Establishment Accept* message.
- Signaling towards the base station requires the AMF to transfer messages using Next Generation Application Protocol (NGAP)
- AMF and Base Station are responsible for managing NGAP signaling procedures but content is relayed to and from the SMF when those procedures relate to Session Management [22]

### **2-2-2-IP Address Allocation:**

Depends upon the type of PDU Session, A PDU session can be setup to transfer either IPv4, IPv6, Ethernet or Unstructured data types.

UE can request a specific data type within the *NAS: PDU Session Establishment Request* message. The allocated data type is confirmed within the *NAS: PDU Session Establishment Accept* message.

IP address allocation is applicable to PDU Sessions which transfer IPv4 or IPv6 packets.

### **2-2-3-GTP-U Tunnel Management:**

Refers to the management of user plane GTP-U tunnel between the Base Station and UPF.

GTP-U tunnels are used to transfer user plane data between the Base Station and UPF.

A GTP-U tunnel operates by adding a set of IP/UDP/GTP-U headers to the user plane data packets. The IP layer is used to route the packets between the Base Station and UPF. The UDP layer is used to provide connectionless data transfer and to specify the port number for the GTP-U layer.

The GTP-U layer specifies the Tunnel Endpoint Identifier (TEID) which links the user plane packet to a specific PDU Session.

General concept of GTP-U tunnel is illustrated below:

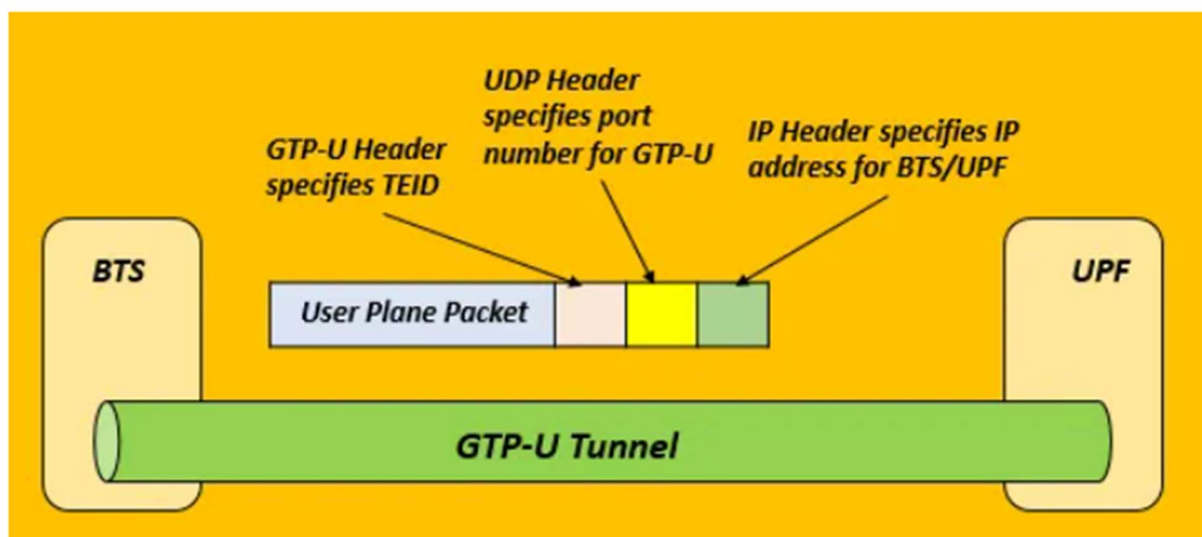

**Figure 20: Illustration of GTP-U Tunnel between the Base Station and User Plane Function (UPF)**

*\*User plane packet include its own IP header if the PDU session data type is IP. The additional IP header is only used to route the packet through the GTP-U tunnel and is removed by the UPF or base station*

### **2-2-4-Downlink Notification Management :**

Refers to the initiation of paging procedure.

- A UE needs to be paged if downlink data arrives at UPF after UE has been released to RRC Idle mode.
- UPFrecognises that the UE does not a GTP-U tunnel towards the Base Station. It triggers the UPF to inform the SMF that downlink data has arrived for the UE.
- SMF eventually informs the AMF from where the Network Triggered Service Request procedure is initiated or UE is paged.

### **2-3-UPF ( user plane function):**

The User Plane Function (UPF) is one of the network functions and a fundamental component, The UPF is responsible for packet routing and forwarding, packet inspection, QoS handling, and external PDU session for interconnecting Data Network (DN), in the 5G architecture.

the important functions of UPF is :

1. packet routing and forwarding
2. Anchor Point for Intra-RAT and Inter-RAT Mobility
3. Enforces quality of service and policy
4. Connects to SMF for session related aspect

### **2-4- PCF (policy control function):**

This function supports the unified policy framework that governs network behaviour. In so doing, it provides policy rules to control plane function(s) to enforce them.

the important functions of PCF is :

1. Dynamic policy decisions
2. Ability to alter mobility and session related service aspects
3. Provides policy rules to control plans NF
4. Connects to SMF,UDM and data network

### **2-5- UDM (Unified data management):**

Unified data management (UDM) is a centralized way to control network user data. It is similar to 4G's home subscriber service (HSS), but is cloud-native and designed for 5G. A stateful form stores data locally to where the UDM is running. A stateless form stores data in a unified data repository (UDR).

#### **Functions:**

The UDM manages data for access authorization, user registration, and data network profiles. Subscriber data is provided to the session management function (SMF), which allocates IP addresses and manages user sessions on the network.

Depending on the construction of the 5G architecture, both UDM software and the UDR can send and store data. In a stateless network, user information is stored in the UDR, but the UDM function retrieves the data, sends it to other network functions, and generally manages it. The UDM can do this with many UDR.

The access and mobility function (AMF) receives user information sent through the network. It then forwards the information to the SMF, which uses it to determine what session manager would be best assigned to the user. Consider the SMF as a gateway from the user plane to the control plane of the network.

### **2-6- AUSF (authentication server function):**

The Authentication Server Function (AUSF) is in a home network and performs authentication with a UE. It makes the decision on UE authentication, but it relies on backend service for computing the authentication data and keying materials when 5G-AKA or EAP-AKA' is used.

### **2-7-NEF (network exposure function):**

The 5G Network Exposure Function (NEF) facilitates secure, robust, developer-friendly access to exposed network services and capabilities. . The NEF is an analogous function to the 4G Service Capabilities Exposure Function. A combined SCEF+NEF node is necessary to hide the specific network technology from applications and user devices that can move between 4G and 5G. Therefore, flexibility on the southbound network interfaces is also an essential feature, for integration with 4G core end-points using the Diameter protocol and with 5G core end-points via the service-based interfaces that are specified as part of the new 5G Core Service Based Architecture (SBA).

### **2-8-NRF (network repository function):**

Oracle Communications Cloud Native Core, Network Repository Function (NRF) works as a centralized repository for all the 5G network functions (NFs) in the operator's network. The NRF allows 5G NFs to register and discover each other via a standards-based API. Oracle Communications NRF is a critical component required to implement the new service-based architecture (SBA) in the 5G core.

### **2-9-NSSF (network slice selection function):**

The Network Slice Selection Function (NSSF) selects the Network Slice Instance (NSI) based on information provided during UE attach. A set of Access and Mobility Management Function (AMF) are provided to the UE based on which slices the UE has access to. The Network Exposure Function (NEF) exposes the overall 5G core network services and capabilities.

### **3-PDU SESSION AND QOS FLOW:**

When a UE establishes a PDU session to a DN, a default non-GBR (non Guaranteed Bit Rate) QoS Flow without any Packet Filter is also formed to carry the UE's traffic to the DN and vice versa. The UE or AFs (Application Functions) can create additional QoS Flows with different QoS characteristics using the PDU Session Modification procedures. For example, the UE can initiate a PDU Session Modification to create a new GBR QoS Flow for a video conference session with criteria such as: [24]

- UDP port = 1234
- latency < 10ms
- UL/DL bandwidth = 2 Mbps GBR
- etc...

### **3-1-PDU Session Establishment Message Sequence**

In order for a PDU session and a default QoS Flow to be established along the UE, gNB to UPF to carry SDFs (Service Data Flows) or traffic, a lot of IEs (Information Elements) are

exchanged among AMF, SMF, UE, gNB and UPF as shown in the Figure below

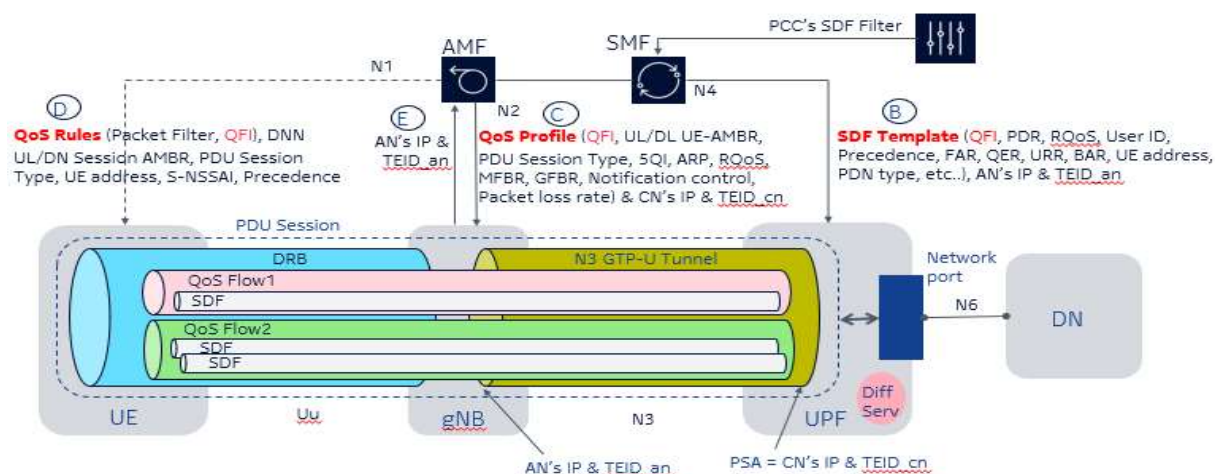

**Figure 21: SDF Template, QoS Profile and QoS Rule for UPF, gNB and UE respectively**

The SMF directly and indirectly (i.e., via the AMF and the gNB) sends the below QoS constructs for the PDU Session and the default QoS Flow Establishment:

- *SDF Template* to UPF
- *QoS Profile* to gNB
- *QoS Rule* to UE

Beside setting up the PDU Session and the default QoS Flow comprising a non-GBR Data Radio Bearer (DRB) between the UE and the gNB and the N3 GTP-U tunnel between gNB and UPF, the above IEs in the Figure 1 are also used for QoS processing and enforcement of the UE's traffic such as:

- Classification — Classify or detect the UE's uplink (UL) and downlink (DL) traffic onto the appropriate QoS Flows within the UE's PDU session
- Queuing and Scheduling — Enforce GBR and non-GBR UE traffic such as UL/DL bandwidth, latency, traffic priority etc...
- Marking/Remarking — Mark the mobile traffic when it leaves the 5GC to the DN so that the priority and QoS of the traffic can be honored in the DN
- We will explain the IEs in the Figure 1 in details when we examine the Wireshark traces in the below sections.

## Chapter III: 5G Quality of service

Release 16

87

3GPP TS 23.502 V16.4.0 (2020-03)

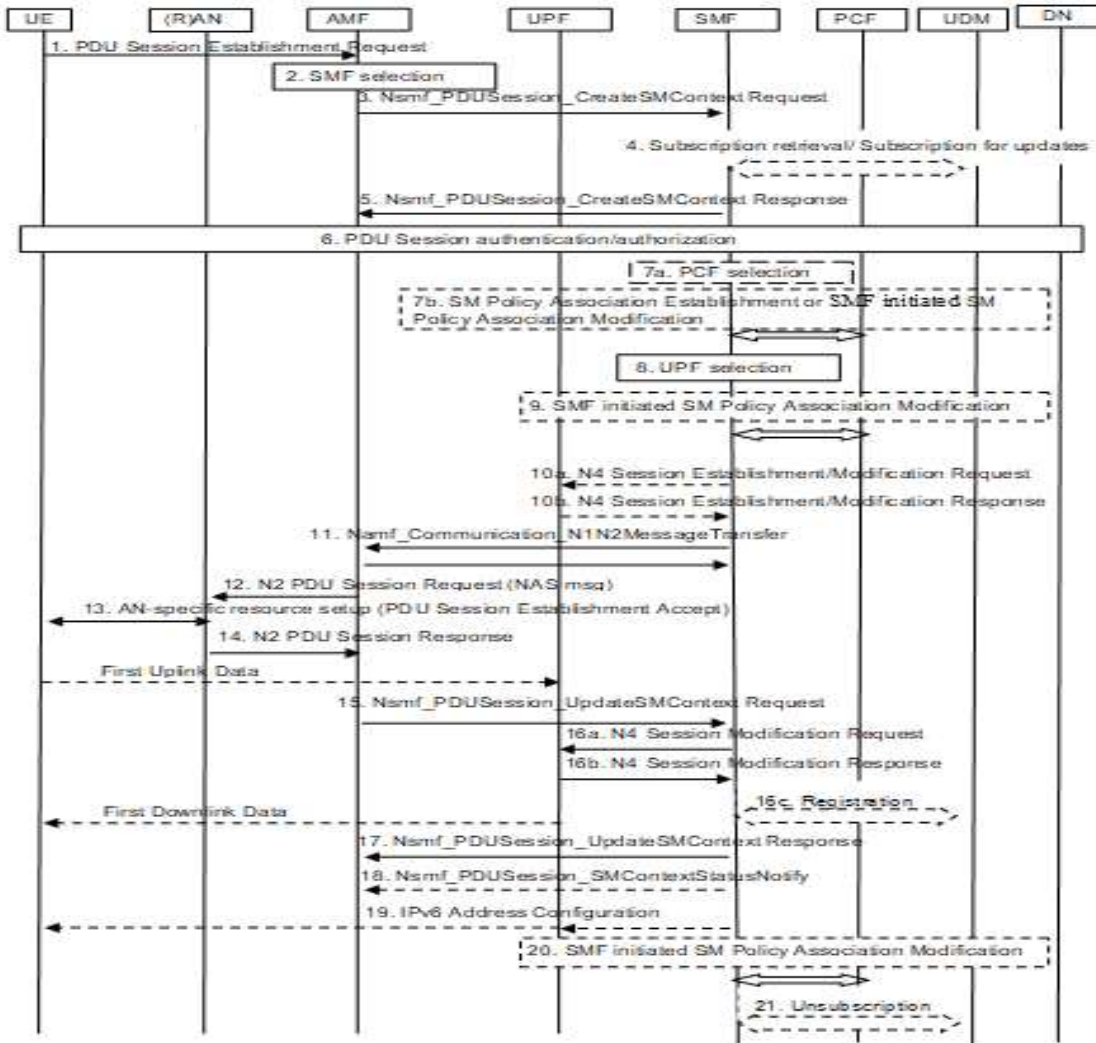

*Figure 22: UE-requested PDU Session Establishment for non-roaming and roaming with local*

### 4-5G QoS Architecture:

In 5G NR, QoS is enforced at the QoS flow level. Each QoS flow packets are classified and marked using QoS Flow Identifier (QFI). The 5G QoS flows are mapped in the Access Network to DRBs (Data Radio Bearers) unlike in 4G where mapping is one to one between EPC and RadioBearers. 5G QoS architecture supports Following QoS flow types [23]

- GBR QoS flow which requires guaranteed flow bit rate
- Non-GBR QoS flow which does not require guaranteed flow bit rate
- Delay Critical QoS flow, For Mission Critical guaranteed flow bit rate

The QoS architecture in 5G, 5G RAN is connected to 5G Core as it is depicted in following figure. Here we can see following:

- 5G Core establishes one or more PDU Sessions for each UEs.
- 5G-RAN establishes at least one Data Radio Bearers (DRB) together with the PDU Session and additional DRB(s) for QoS flow(s) of that PDU session can be subsequently configured for each UEs.
- 5G-RAN maps packets belonging to different PDU sessions to different DRBs
- NAS level packet filters in the UE and in the 5GC associate UL and DL packets with QoS Flows.
- AS level mapping rules in the UE and in the 5G-RAN associate UL and DL QoS Flows with DRBs.

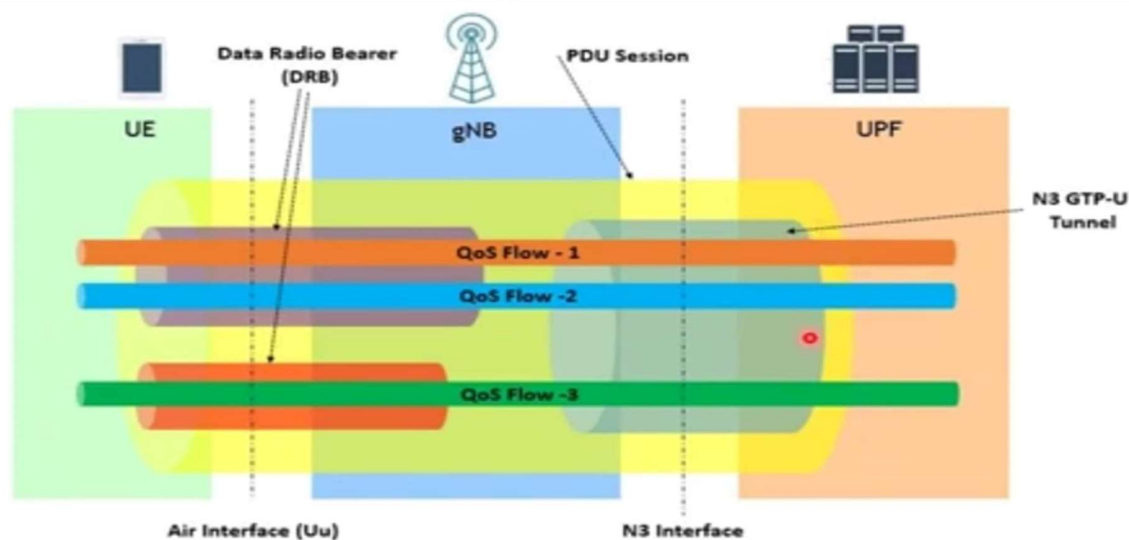

*Figure 23: 5G QoS Architectur*

### 5- 5G QoS Flow to DRB Mapping:

In legacy 4G network, the DRB, EPS Bearer, S1 GTP-U and S5-U tunnel has a one-to-one mapping, but in the 5GC, there is only a single user plane network function the UPF for transport of data between the gNB and the core so following mapping is opted. [25]

- DRBs on air interface can have One-to-many relationship with the GTP-U tunnel on N3 interface at UPF.
- Each QoS flow is mapped to a single GTP-U tunnel at N3 interface.
- gNB may map individual QoS flows to one more DRBs.
- A PDU session may contain multiple QoS flows and several DRBs but only a single N3 GTP-U tunnel.
- A DRB may transport one or more QoS flows.
- The QFI that identifies the flow is carried in an extension header on N3 in the GTP-U protocol, using DL and UL PDU session information frames.
- The DL and UL PDU session information frame includes a QoS Flow Identifier (QFI) field for each packet.
- The DL PDU session information frame includes the Reflective QoS Indicator (RQI) field to indicate whether the user plane reflective QoS is to be activated or not. This is only applicable if reflective QoS is inactivated.

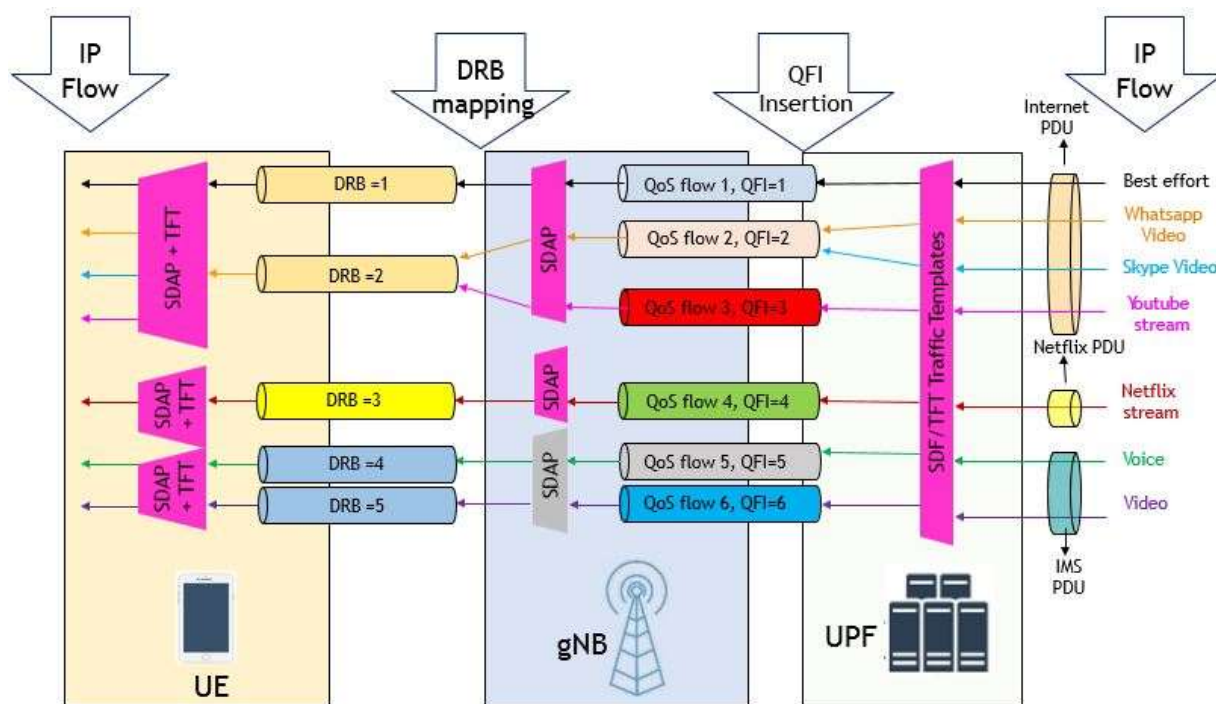

Figure 24: QoS Flow to DRB Mapping

## 6- 5G PROTOCOL LAYERS

The 5G NR radio access network is comprised of these protocol entities:

- Service data adaptation protocol (SDAP)
- Packet data convergence protocol (PDCP)
- Radio link control (RLC)
- Medium access control (MAC)
- Physical layer (PHY)

The SDAP protocol is new in 5G NR compared to the LTE protocol stack. SDAP handles the new QoS framework of the 5G System (in the 5G Core). SDAP applies also to LTE when connected to the 5G Core. The introduction of SDAP enables end-to-end QoS framework that works in both directions.

To meet the desired key capabilities of 5G NR, the other layers of the stack provide various enhancements over their LTE counterparts. The PDCP, RLC, and MAC protocols handle tasks such as header compression, ciphering, segmentation and concatenation, and multiplexing and

## Chapter III: 5G Quality of service

demultiplexing. PHY handles coding and decoding, modulation and demodulation, and antenna mapping.

This figure shows the 5G NR user plane protocol stack for user equipment (UE) and the NR radio access network node (gNB). 5G Toolbox™ supports the 5G NR physical layer, including physical channels and signals. The toolbox also supports interfacing with portions of the RLC and MAC layers, including transport channels and logical channels

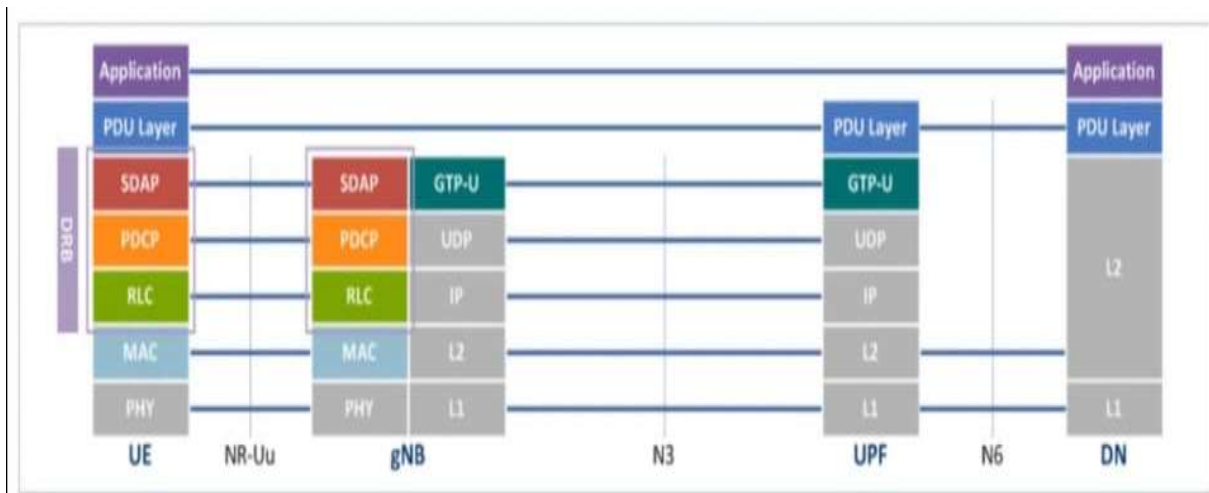

**Figure 25: 5G PROTOCOL LAYERS**

### 7- Default QoS Flow:

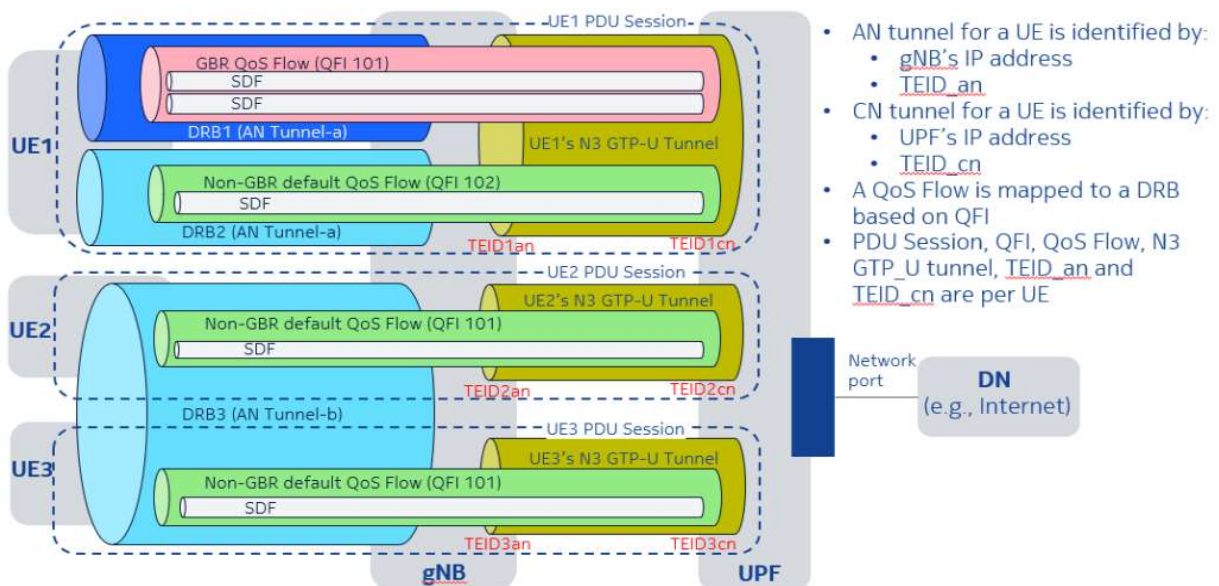

**Figure 26: QoS Flow**

The default QoS Flow is usually a non-GBR (non-Guaranteed Bit Rate) QoS Flow without any Packet Filter. Also, it has the lowest *Precedence* in term of traffic mapping. In other words, if uplink (UL) or downlink (DL) traffic do not match any Packet Filters in the other QoS Flows within a UE's PDU Session, the default QoS Flow will be used to forward the UE traffic to the DN and vice versa. The default QoS Flow can also be used by a UE to signal an AF (Application Function) such as voice or video servers to establish GBR QoS Flows to support more QoS demanding network applications such as video conferencing or real-time robotic traffic.

In the above diagram, UE1, UE2 and UE3 each has a default QoS Flow to the DN. A SDF (Service Data Flow) is a traffic stream between a UE and the DN where the SDF's QoS requirements can be satisfied by the QoS Flow carrying the SDF beside the default QoS Flow, UE1 may also need a GBR (Guaranteed Bit Rate) QoS Flow to carry its, say video conference traffic. Therefore, UE1 signals a separate GBR QoS Flow using its default QoS Flow to the video conference server or AF (Application Function) where the AF will initiate a QoS Flow setup to the PCF for it to generate a *PCC Rule* to the SMF. This *PCC Rule* triggers the SMF to perform a PDU Session Modification procedure to either modify an existing or create a new QoS Flow suitable for the video conference traffic or SDF. Since UE1 does not yet have any GBR QoS Flow, a new GBR QoS Flow among UE1, gNB, and UPF for carrying the video conference traffic is signaled and established by the SMF.

For a successful PDU session established between a UE and a DN, the following wireless and wireline tunnels are setup:

- A bi-directional wireless Data Radio Bearer (DRB) between UE and gNB.
- Two uni-directional GTP-U tunnels to form a bi-directional N3 GTP-U tunnel between gNB and UPF.

### **8-QOS Types and Parameters:**

3GPP specification 23.501 defined the following 5G QoS Parameters as part of QoS Implementation.

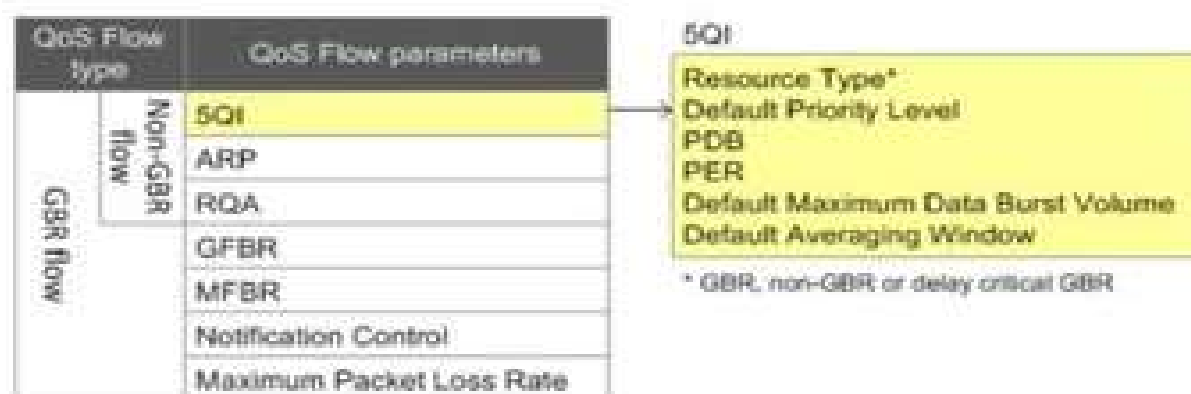

Figure 27: QoS Types and Parameters

### 8-1- 5G QoS Identifier (5GQI):

A 5QI is a scalar that is used as a reference to 5G QoS characteristics i.e. access node-specific parameters that control QoS forwarding treatment for the QoS Flow (e.g. scheduling weights, admission thresholds, queue management thresholds, link layer protocol configuration, etc.). [25]

- Standardized 5QI values have one-to-one mapping to a standardized combination of 5G QoS characteristics .
- The 5G QoS characteristics for pre-configured 5QI values are pre-configured in the Access Node (gNB).
- Standardized or pre-configured 5G QoS characteristics, are indicated through the 5QI value, and are not signalled on any interface, unless certain 5G QoS characteristics are modified .
- The 5G QoS characteristics for QoS Flows with dynamically assigned 5QI are signalled as part of the QoS profile.

### 8-2-Allocation and Retention Priority (ARP):

The QoS parameter ARP contains information about the priority level, the pre-emption capability and the pre-emption vulnerability. The ARP priority level defines the relative importance of a resource request to allows in deciding whether a new QoS Flow may be accepted or needs to be rejected in the case of resource limitations (typically used for admission control of

GBR traffic). It may also be used to decide which existing QoS Flow to pre-empt during resource limitations. ARP has following characteristics:

- The range of the ARP priority level is 1 to 15 with 1 as the highest level of priority.
- The ARP priority levels 1-8 should only be assigned to resources for services that are authorized to receive prioritized treatment within an operator domain (i.e. that are authorized by the serving network).
- The ARP priority levels 9-15 may be assigned to resources that are authorized by the home network and thus applicable when a UE is roaming.
- The ARP pre-emption capability defines whether a service data flow may get resources that were already assigned to another service data flow with a lower ARP priority level
- The ARP pre-emption capability and the ARP pre-emption vulnerability shall be either set to 'enabled' or 'disabled'.
- The ARP pre-emption vulnerability defines whether a service data flow may lose the resources assigned to it in order to admit a service data flow with higher ARP priority level
- The ARP pre-emption vulnerability of the QoS Flow which the default QoS rule is associated with should be set appropriately to minimize the risk of unnecessary release of this QoS Flow.

### **8-3-Reflective QoS Attribute (RQA) :**

The RQA is an optional parameter which indicates that certain traffic (not necessarily all) carried on this QoS Flow is subject to Reflective QoS. Only when the RQA is signalled for a QoS Flow, the RAN/AN enables the transfer of the RQI for AN resource corresponding to this QoS Flow. The RQA may be signalled to NG-RAN via the N2 reference point at UE context establishment in NG-RAN and at QoS Flow establishment or modification. [23]

### **8-4-Notification Control:**

The QoS Parameter Notification control indicates whether notifications are requested from the NG-RAN when the GBR can no longer (or can again) be guaranteed for a QoS Flow during the lifetime of the QoS Flow. Notification control may be used for a GBR QoS Flow if the application traffic is able to adapt to the change in the QoS (e.g. if the AF is capable to trigger rate adaptation).

### **8-5-Flow Bit Rates:**

For GBR QoS Flows only, the additional QoS parameters are Guaranteed Flow Bit Rate (GFBR) and Maximum Flow Bit Rate (MFBR) applicable for Uplink and Downlink.

- The GFBR denotes the bit rate that is guaranteed to be provided by the network to the QoS Flow over the Averaging Time Window.
- The MFBR limits the bit rate to the highest bit rate that is expected by the QoS Flow (e.g. excess traffic may get discarded or delayed by a rate shaping or policing function at the UE, RAN, UPF).

Bit rates above the GFBR value and up to the MFBR value, may be provided with relative priority determined by the Priority Level of the QoS Flows. GFBR and MFBR are signalled to the (R)AN in the QoS Profile and signalled to the UE as QoS Flow level QoS parameter for each individual QoS Flow.

### **8-6- Maximum Packet Loss Rate:**

The Maximum Packet Loss Rate (UL, DL) indicates the maximum rate for lost packets of the QoS flow that can be tolerated in the uplink and downlink direction. . This is provided to the QoS flow if it is compliant to the GFBR.

### **9- 5G QoS Flow Characteristics:**

5G QoS characteristics describe the packet forwarding treatment that a QoSFlow receives edge-to-edge between the UE and the UPF in terms of the following performance characteristics:

- Resource Type (GBR, Delay critical GBR or Non-GBR)
- PriorityLevel
- Packet Delay Budget(including core network packet delay budget)
- PacketError Rate
- Averaging window (for GBR and Delay-critical GBR resource type only)
- Maximum Data Burst Volume (for Delay-critical GBR resource type only)

## Chapter III: 5G Quality of service

The 5GQoS characteristics should be understood as guidelines for setting node specific parameters for each QoS Flow e.g. for 3GPP radio access link layer protocol configurations. Standardized or pre-configured 5G QoS characteristics, are indicated through the 5QI value, and are not signalled on any interface, unless certain 5GQoS characteristics are modified.

### 10- Standard values of 5QI:

5QI Value	Resource Type	Default Priority Level	Packet Delay Budget (NOTE 3)	Packet Error Rate	Default Maximum Data Burst Volume (NOTE 2)	Default Averaging Window	Example Services
1	GBR (NOTE 1)	20	100 ms (NOTE 11, NOTE 13)	$10^{-2}$	N/A	2000 ms	Conversational Voice
2		40	150 ms (NOTE 11, NOTE 13)	$10^{-3}$	N/A	2000 ms	Conversational Video (Live Streaming)
3		30	50 ms (NOTE 11, NOTE 13)	$10^{-3}$	N/A	2000 ms	Real Time Gaming, V2X messages (see TS 23.287 [121]). Electricity distribution – medium voltage, Process automation monitoring
...		...	...	...	...	...	...
5	Non-GBR (NOTE 1)	10	100 ms NOTE 10, NOTE 13)	$10^{-6}$	N/A	N/A	IMS Signalling
6		60	300 ms (NOTE 10, NOTE 13)	$10^{-6}$	N/A	N/A	Video (Buffered Streaming) TCP-based (e.g., www, e-mail, chat, ftp, p2p file sharing, progressive video, etc.)
7		70	100 ms (NOTE 10, NOTE 13)	$10^{-3}$	N/A	N/A	Voice, Video (Live Streaming) Interactive Gaming
...		...	...	...	...	...	...
82	Delay-critical GBR	19	10 ms (NOTE 4)	$10^{-4}$	255 bytes	2000 ms	Discrete Automation (see TS 22.261 [2])
83		22	10 ms (NOTE 4)	$10^{-4}$	1354 bytes (NOTE 3)	2000 ms	Discrete Automation (see TS 22.261 [2]); V2X messages (UE - RSU Platooning, Advanced Driving: Cooperative Lane Change with low LoA. See TS 22.186 [111], TS 23.287 [121])
84		24	30 ms (NOTE 6)	$10^{-5}$	1354 bytes (NOTE 3)	2000 ms	Intelligent transport systems (see TS 22.261 [2])
...		...	...	...	...	...	...

**Figure 28: Standard values of 5QI**

An extract of some 5QI values and their QoS characteristics. Source: Adapted from ETSI 2021a, table 5.7.4-1.

## Chapter III: 5G Quality of service

Specification TS 23.501 defines some 5QI values that translate to QoS characteristics commonly used. This leads to optimized signaling, that is, specifying the 5QI value is sufficient, though default values can be modified. For non-standard 5QI values, QoS characteristics need to be signaled as part of the QoS profile.

SMF signals QoS profiles to NG-RAN via AMF. QoS characteristics in these profiles are in fact guidelines to the NG-RAN to configure suitable RBs to carry QoS flows.

There are about two dozen standard 5QI values, grouped into three resource types: Guaranteed Bit Rate (GBR), Non-GBR, Delay-critical GBR. QoS characteristics include resource type, priority level (lower number implies higher priority), Packet Delay Budget (PDB), Packet Error Rate (PER), averaging window (for GBR and delay-critical GBR only), and Maximum Data Burst Volume (MDBV) (for delay-critical GBR only).

Conversational voice (5QI=1) has 100ms PDB and 0.01 PER. Real-time gaming (5QI=3) has 50ms PDB and a lower priority. IMS signaling (5QI=5) has stringent PER of 0.000001. Discrete automation (5QI=82) has stringent PDB of 10ms.[26]

### 11- 5G and 4G QoS Parameters Comparison:

Below picture and table shows a high level different regarding 5G and 4G QoS Parameters.[26]

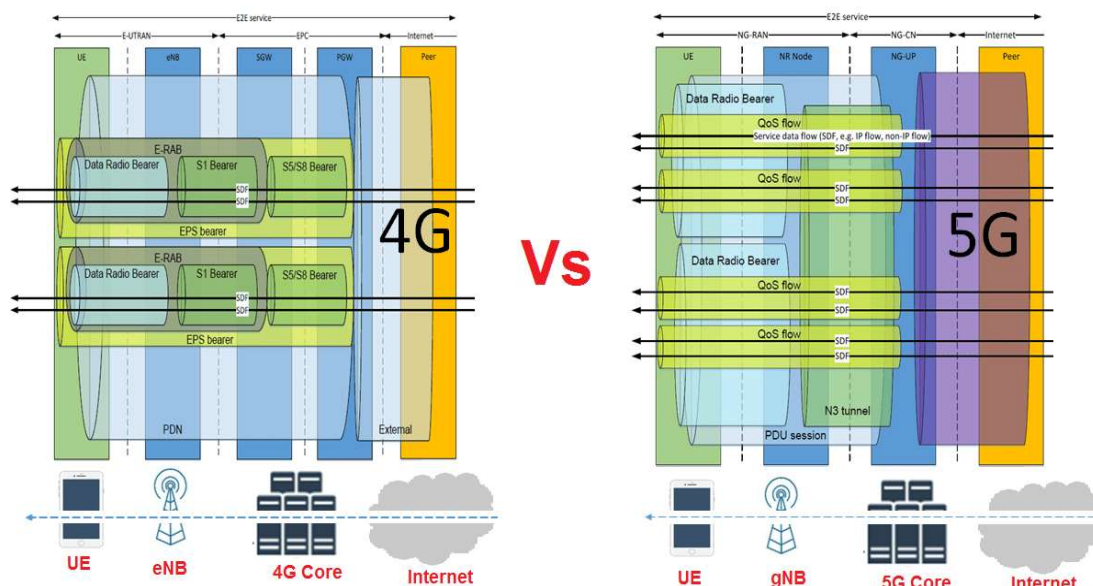

**Figure 29: 5G and 4G QoS parameters Comparison**

### Chapter III: 5G Quality of service

---

in 4G, QoS differentiation requires establishing different EPS bearers, each with different QCI as all user plane data transferred using the same EPS Bearer has the same QoS, which brings high signaling overhead as each EPS bearer establishment is done between UE and PGW.

The 5G QoS model is based on QoS Flows, no bearers in 5G. The QoS flow is the finest granularity of QoS differentiation in the PDU session compared to the 4G QoS which is based on the static bearer concept and this allows the 5G QoS to be assured on application basis, so we can create a QoS flow for each application and QoS flows are created dynamically without the need for E2E signaling. Also, short lived QoS flows (e.g., low latency requirements) can receive differentiated QoS treatment without the overhead of establishing EPS bearers from E2E and then release it again and so on

<b>Parameter</b>	<b>5G</b>	<b>4G</b>
<b>QoS Identifier</b>	5G QI (QoS Identifier)	QCI (QoS Class Identifier)
<b>IP Data Flow</b>	QoS Flow	EPC Bearer
<b>Flow/Bearer Identifier</b>	QFI (QoS Flow Identifier )	EBI (EPS Bearer ID)
<b>Reflective QoS</b>	RQI (Reflective QoS ID)	Not Applicable
<b>Data Session</b>	PDU Session	PDN Connection

*Table 5: 5G and 4G QoS Parameters*

## 12- Comparison between the LTE and 5G QoS architecture

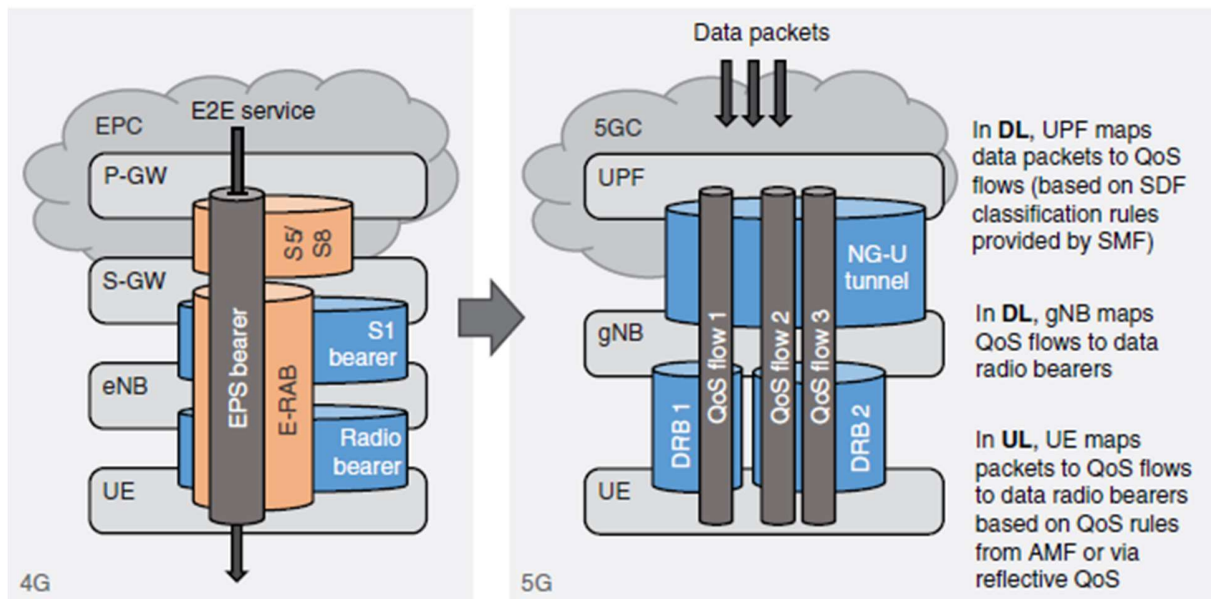

*Figure 30: 5G and 4G QoS parameters Comparison architecture*

In the LTE case, on the left side, we can see the bearer-oriented approach with a strict one-to-one mapping between EPS-bearers, EPS radio access bearers (E-RAB), S1 and radio bearers.

In the 5G case, on the right side, we see the flow-based approach which allows to decouple the assignment of packets to flows (controlled by the CN) from the assignment of flows to DRBs (being in the responsibility of the RAN).

The particular example of three different QoS flows mapped to two different DRBs is here to be seen as an example only. Note that in the context of introducing the new QoS architecture, 3GPP has also agreed to introduce a new UP protocol layer in the RAN above Packet Data Convergence Protocol (PDCP), called Service Data Adaptation Protocol (SDAP). This is responsible to map QoS flows to radio bearers and mark the QoS flow in uplink (UL) and downlink (DL) packets.[26]

#### **Conclusion:**

In this section, we looked at how to model a 5G network and QoS using performance parameters, with the goal of determining what contexts each model might be used in. This network's measurable QoS characteristics are also explained in depth. how can it be developed? These characteristics can only improve to the point when network subscribers are satisfied in terms of QoS. These QoS parameters will be evaluated and improved.

# **Chapter IV:**

## **Simulation**

### Chapter IV: Simulation

#### 1- Objective:

In order to improve the QoS related to Wireless network, we have several ways to do it. In Our case, we chouse to focus on the antenna. enhanced. So in this section we are going to simulate two antenna technologies uses case:

- First one is a classic singal antenna.
- The second one is a 5G Massive-MiMo antenna.

#### 2- Simulation Tool Matlab:

MATLAB is a high-performance language for technical computing. It integrates computation, visualization, and programming in an easy-to-use environment where problems and solutions are expressed in familiar mathematical notation. Typical uses include:

- Math and computation
- Algorithm development
- Modeling, simulation, and prototyping
- Data analysis, exploration, and visualization
- Scientific and engineering graphics
- Application development, including Graphical User Interface building

MATLAB is an interactive system whose basic data element is an array that does not require dimensioning. This allows you to solve many technical computing problems, especially those with matrix and vector formulations, in a fraction of the time it would take to write a program in a scalar noninteractive language such as C or Fortran.

The name MATLAB stands for matrix laboratory. MATLAB was originally written to provide easy access to matrix software developed by the LINPACK and EISPACK projects, which together represent the state-of-the-art in software for matrix computation.

MATLAB has evolved over a period of years with input from many users. In university environments, it is the standard instructional tool for introductory and advanced courses in mathematics, engineering, and science. In industry, MATLAB is the tool of choice for high-productivity research, development, and analysis.

MATLAB features a family of application-specific solutions called toolboxes. Very important to most users of MATLAB, toolboxes allow you to learn and apply specialized technology. Toolboxes are comprehensive collections of MATLAB functions (M-files) that extend the MATLAB environment to solve particular classes of problems. Areas in which toolboxes are available include signal processing, control systems, neural networks, fuzzy logic, wavelets, simulation, and many others

### 3- Simulation steps:

#### 3-1- First case:

In the system diagram shown below, each antenna is connected to a unique transmit and receive (TR) module.

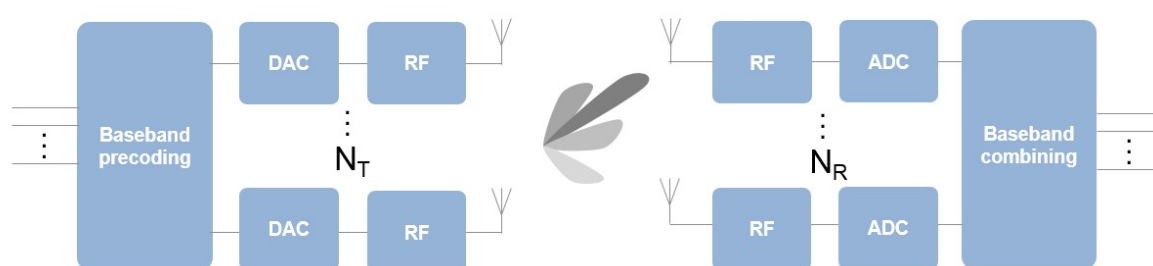
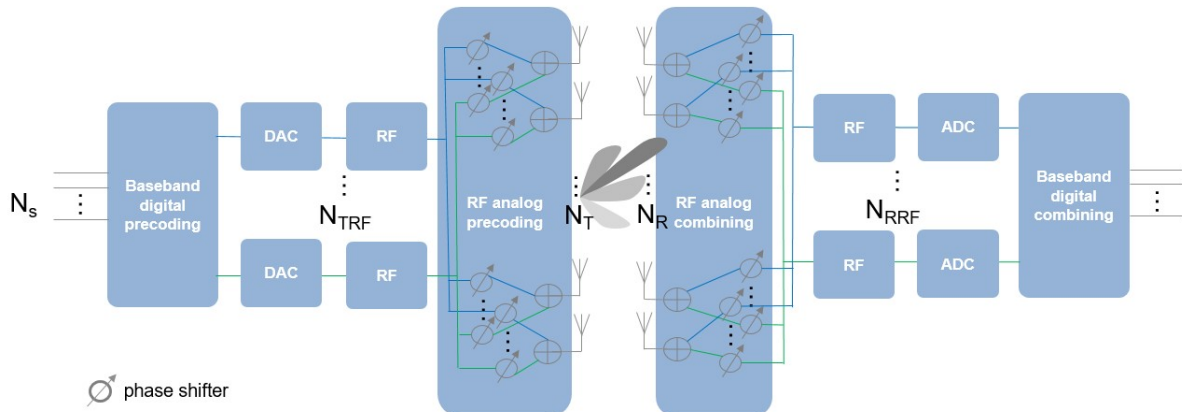

*Figure 31: Transmit and Receive (TR) module*

#### 3-2- Second case:

5G, wireless systems will use millimeter wave (mmWave) band to take advantage of its wider bandwidth. In addition, 5G systems deploy large scale antenna arrays to mitigate severe propagation loss in the mmWave band. However, these configurations bring their unique technical challenges.

Compared to current wireless systems, the wavelength in the mmWave band is much smaller. Although this allows an array to contain more elements with the same physical dimension, it becomes much more expensive to provide one TR module for each antenna element. Hence, as a compromise, a TR switch is often used to supply multiple antenna elements. This is the same concept as the subarray configuration used in the radar community. One such configuration is shown in the following figure.



**Figure 32: Hybrid Beamforming Modul**

The figure above shows that on the transmit side, the number of TR switches,  $N_{TRF}$ , is smaller than the number of antenna elements,  $N_T$ . To provide more flexibility, each antenna element can be connected to one or more TR modules. In addition, analog phase shifters can be inserted between each TR module and antenna to provide some limited steering capability.

The configuration on the receiver side is similar, as shown in the figure. The maximum number of data streams,  $N_S$ , that can be supported by this system is the smaller of  $N_{TRF}$  and  $N_{RRF}$ .

In this configuration, it is no longer possible to apply digital weights on each antenna element. Instead, the digital weights can only be applied at each RF chain. At the element level, the signal is adjusted by analog phase shifters, which only changes the phase of the signal. Thus, the precoding or combining are actually done in two stages. Because this approach performs beamforming in both digital and analog domains, it is referred to as hybrid beamforming.

This section simulates a 64 x 16 MIMO hybrid beamforming system, with a 64-element square array with 4 RF chains on the transmitter side and a 16-element square array with 4 RF chains on the receiver side.

```
Nt = 64;

NtRF = 4;

Nr = 16;
```

## Chapter IV: Simulation

```
NrRF = 4;
```

In this simulation, it is assumed that each antenna is connected to all RF chains. Thus, each antenna is connected to 4 phase shifters. Such an array can be modeled by partitioning the array aperture into 4 completely connected subarrays.

```
rng(4096);

c = 3e8;

fc = 28e9;

lambda = c/fc;

txarray = phased.PartitionedArray('Array',phased.URA([sqrt(Nt)
sqrt(Nt)],lambda/2),'SubarraySelection',ones(NtRF,Nt),'SubarraySteering','Custom');

rxarray = phased.PartitionedArray('Array',phased.URA([sqrt(Nr)
sqrt(Nr)],lambda/2),'SubarraySelection',ones(NrRF,Nr),'SubarraySteering','Custom');
```

To maximize the spectral efficiency, each RF chain can be used to send an independent data stream. In this case, the system can support up to 4 streams.

Next, assume a scattering environment with 6 scattering clusters randomly distributed in space. Within each cluster, there are 8 closely located scatterers with a angle spread of 5 degrees, for a total of 48 scatterers. The path gain for each scatterer is obtained from a complex circular symmetric Gaussian distribution.

```
Ncl = 6;

Nray = 8;

Nscatter = Nray*Ncl;

angspread = 5;

% compute randomly placed scatterer clusters

txclang = [rand(1,Ncl)*120-60;rand(1,Ncl)*60-30];
```

## Chapter IV: Simulation

```
rxclang = [rand(1,Ncl)*120-60;rand(1,Ncl)*60-30];

txang = zeros(2,Nscatter);

rxang = zeros(2,Nscatter);

% compute the rays within each cluster

for m = 1:Ncl

txang(:,(m-1)*Nray+(1:Nray)) = randn(2,Nray)*sqrt(angspread)+txclang(:,m);

rxang(:,(m-1)*Nray+(1:Nray)) = randn(2,Nray)*sqrt(angspread)+rxclang(:,m);

end

g = (randn(1,Nscatter)+1i*randn(1,Nscatter))/sqrt(Nscatter)

txpos = getElementPosition(txarray)/lambda;

rxpos = getElementPosition(rxarray)/lambda;

H = scatteringchanmtx(txpos,rxpos,txang,rxang,g);
```

### 3-4- Hybrid Weights Computation

In a spatial multiplexing system with all digital beamforming, the signal is modulated by a set of precoding weights, propagated through the channel, and recovered by a set of combining weights. Mathematically, this process can be described by  $Y = (X*F*H+N)*W$  where  $X$  is an  $N_s$ -column matrix whose columns are data streams,  $F$  is an  $N_s \times N_t$  matrix representing the precoding weights,  $W$  is an  $N_r \times N_s$  matrix representing the combining weights,  $N$  is an  $N_r$ -column matrix whose columns are the receiver noise at each element, and  $Y$  is an  $N_s$ -column matrix whose columns are recovered data streams. Since the goal of the system is to achieve better spectral efficiency, obtaining the precoding and combining weights can be considered as an optimization problem where the optimal precoding and combining weights make the product of  $F*H*W'$  a diagonal matrix so each data stream can be recovered independently.

## Chapter IV: Simulation

---

In a hybrid beamforming system, the signal flow is similar. Both the precoding weights and the combining weights are combinations of baseband digital weights and RF band analog weights. The baseband digital weights convert the incoming data streams to input signals at each RF chain and the analog weights then convert the signal at each RF chain to the signal radiated or collected at each antenna element. Note that the analog weights can only contain phase shifts.

Mathematically, it can be written as  $F = F_{bb} * F_{rf}$  and  $W = W_{bb} * W_{rf}$ , where  $F_{bb}$  is an  $N_s \times N_{tRF}$  matrix,  $F_{rf}$  an  $N_{tRF} \times N_t$  matrix,  $W_{bb}$  an  $N_rRF \times N_s$  matrix, and  $W_{rf}$  an  $N_r \times N_rRF$  matrix. Since both  $F_{rf}$  and  $W_{rf}$  can only be used to modify the signal phase, there are extra constraints in the optimization process to identify the optimal precoding and combining weights. Ideally, the resulting combination of  $F_{bb} * F_{rf}$  and  $W_{rf} * W_{bb}$  are close approximations of  $F$  and  $W$  that are obtained without those constraints.

Unfortunately, optimizing all four matrix variables simultaneously is quite difficult. Therefore, many algorithms are proposed to arrive at suboptimal weights with a reasonable computational load. This example uses the orthogonal matching pursuit algorithm to derive the precoding weights. Once the precoding weights are computed, the result is then used to obtain the corresponding combining weights.

Assuming the channel is known, the unconstrained optimal precoding weights can be obtained by diagonalizing the channel matrix and extracting the first  $N_{tRF}$  dominating modes. The transmit beam pattern can be plotted as.

```
F = diagbweights(H);  
  
F = F(1:NtRF,:);  
  
pattern(txarray,fc,-90:90,-  
90:90,'Type','efield','ElementWeights',F,'PropagationSpeed',c);
```

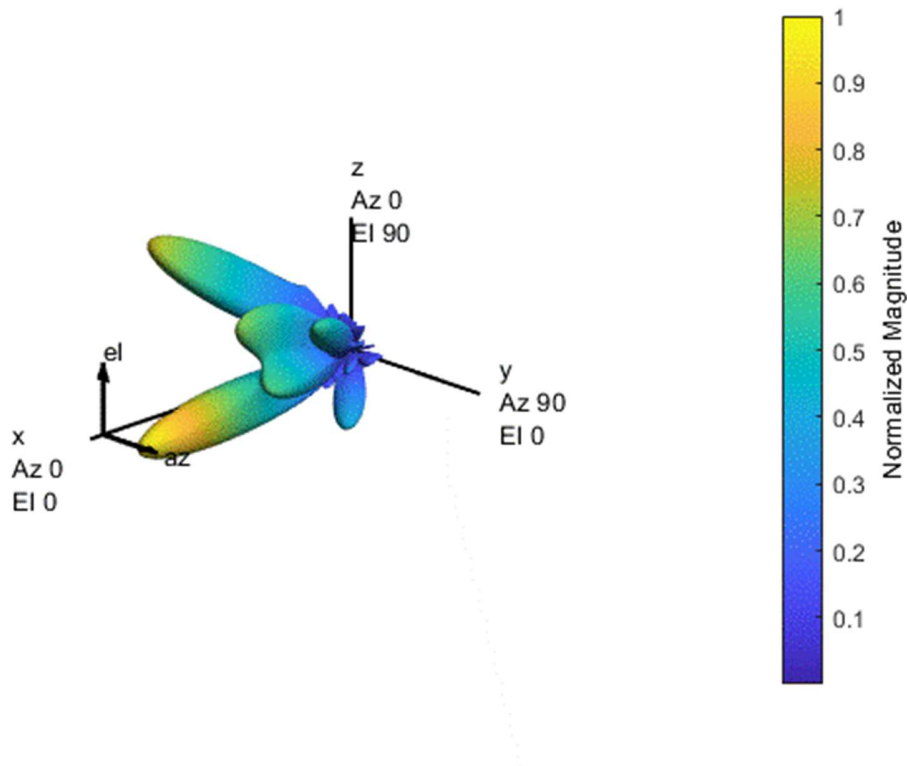

**Figure 33: First 3D Reponse pattern**

The response pattern above shows that even in a multipath environment, there are limited number of dominant directions.

The hybrid weights, on the other hand, can be computed as

```
At = steervec(txpos,txang);

Ar = steervec(rxpos,rxang);

Ns = NtRF;

[Fbb,Frff] = omphybweights(H,Ns,NtRF,At);

pattern(txarray,fc,-90:90,-
90:90,'Type','efield','ElementWeights',Frff'*Fbb','PropagationSpeed',c);
```

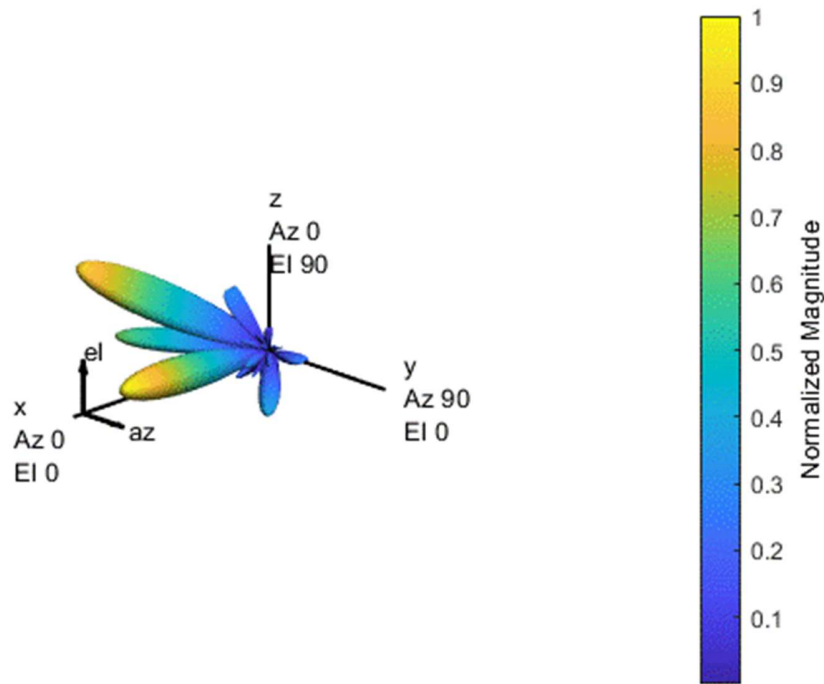

*Figure 34: Second 3D Reponse pattern*

Compared to the beam pattern obtained using the optimal weights, the beam pattern using the hybrid weights is similar, especially for dominant beams. This means that the data streams can be successfully transmitted through those beams using hybrid weights.

### 3-4- Spectral Efficiency Comparison

One of the system level performance metrics of a 5G system is the spectral efficiency. The next section compares the spectral efficiency achieved using the optimal weights with that of the proposed hybrid beamforming weights. The simulation assumes 1 or 2 data streams. The transmit antenna array is assumed to be at a base station, with a focused beamwidth of 60 degrees in azimuth and 20 degrees in elevation. The signal can arrive at the receive array from any direction. The resulting spectral efficiency curve is obtained from 50 Monte-Carlo trials for each SNR.

```
snr_param = -40:5:0;  
  
Nsnr = numel(snr_param);
```

## Chapter IV: Simulation

---

```
Ns_param = [1 2];

NNs = numel(Ns_param);

NtRF = 4;

NrRF = 4;

Ropt = zeros(Nsnr, NNs);

Rhyb = zeros(Nsnr, NNs);

Niter = 50;

for m = 1:Nsnr

    snr = db2pow(snr_param(m));

    for n = 1:Niter

        % Channel realization

        txang = [rand(1, Nscatter)*60-30; rand(1, Nscatter)*20-10];

        rxang = [rand(1, Nscatter)*180-90; rand(1, Nscatter)*90-45];

        At = steervec(txpos, txang);

        Ar = steervec(rxpos, rxang);

        g = (randn(1, Nscatter)+1i*randn(1, Nscatter))/sqrt(Nscatter);

        H = scatteringchanmtx(txpos, rxpos, txang, rxang, g);

        for k = 1:NNs

            Ns = Ns_param(k);

            % Compute optimal weights and its spectral efficiency

            [Fopt, Wopt] = helperOptimalHybridWeights(H, Ns, 1/snr);

            Ropt(m, k) = Ropt(m, k) + helperComputeSpectralEfficiency(H, Fopt, Wopt, Ns, snr);

        end

    end

end
```

## Chapter IV: Simulation

---

```
% Compute hybrid weights and its spectral efficiency

    [Fbb, Frf, Wbb, Wrf] = omphybweights(H, Ns, NtRF, At, NrRF, Ar, 1/snr);

Rhyb(m, k) = Rhyb(m, k) + helperComputeSpectralEfficiency(H, Fbb*Frf, Wrf*Wbb, Ns, snr);

end

end

end

Ropt = Ropt/Niter;

Rhyb = Rhyb/Niter;

plot(snr_param, Ropt(:, 1), '--sr', snr_param, Ropt(:, 2), '--b', snr_param, Rhyb(:, 1), '-sr', snr_param, Rhyb(:, 2), '-b');

xlabel('SNR (dB)');

ylabel('Spectral Efficiency (bits/s/Hz)');

legend('Ns=1 optimal', 'Ns=2 optimal', 'Ns=1 hybrid', 'Ns=2 hybrid', 'Location', 'best');

grid on;
```

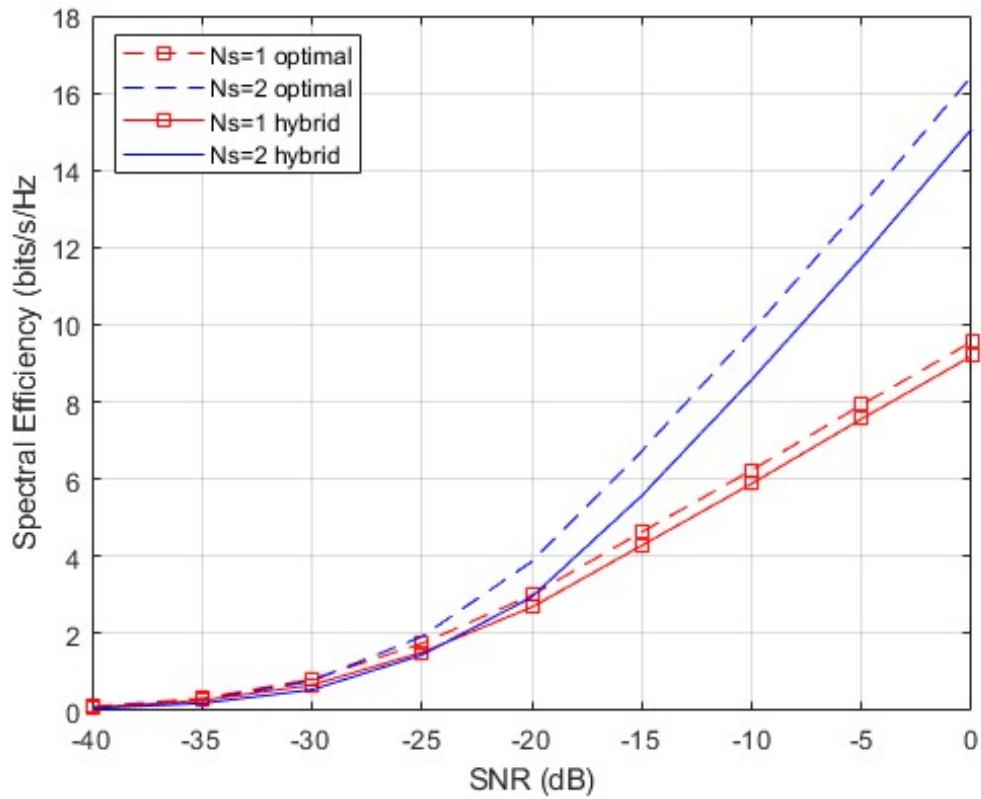

*Figure 35: spectral efficiency Curve*

This figure shows that the spectral efficiency improves significantly when we increase the number of data streams. In addition, the hybrid beamforming can perform close to what optimal weights can offer using less hardware.

### General Conclusion

After the above which presented the different wireless networks evolving after every generation, delivering every time the best experience all in term of speed, quality of the network and the reliability, which leads to the most advanced and development the 5 generation. We saw also the importance function in the networks which is the mobility management and how it is an essential in the networks.

5G networks are not just a development of fourth-generation networks but will become the most widely used standard in the future. For these networks, quality of service is an important concept for managing a comprehensive intellectual property network. The concepts of service modelling based on the principles of prioritization and pre-emption are seen in part II of the present summary. This was followed by information on the organization of the 5G network. The study then continued by explaining the quality of the service and scheduling mechanisms, and we were able to focus on some of the scheduling algorithms.

The final part of the simulation results demonstrated that the quality of service on the radio link was effectively affected by multi-antenna techniques, specifically with regard to production criteria, delay and packet loss, the dose was minimal. One of the techniques studied is Massive-Mimo Beafoming which is in almost all parameters, because it is performance technique and performance quality.

## References

- [1].Tripathi SR (2016) Analysis and survey on past, present and future generation in mobile communication. IOSR J Comput Eng 2: 30-36.
- [2].Tripathi SM, Prasad R (2013) Spectrum trading in India and 5G purnendu. Journal of ICT Standardization 1: 159-174.
- [3].Bhandari N (2017) Evolution of cellular network: from 1G to 5G. Int J Eng Technol 3: 98-105.
- [4].Sucheta P Yadav KP (2013) A Comparative studies of 1G, 2G, 3G and 4G. Int J Adv Eng Res 3: 1-16.
- [5].A Survey Report on Generations of Network: 1G, 2G, 3G, 4G, 5G (2006).
- [6].Khutey R (2015) Future of wireless technology 6G and 7G. Int J Electr Electron Res 3: 583-585.
- [7].Mobile Technology: Evolution from 1G to 4G electronics for you.
- [8].Kachhavay MG Ajay PT (2014) 5G Technology-evolution and
- [9].revolution. Int J comput Scie Mobile Comput 3: 1080-1087.
- [10].Tutorialspoint LTE Network Architecture (2019).
- [11].Tutorialspoint 5G Network Architecture (2019)
- [12].« principe et fonctionnement des réseaux mobiles », SUPCOM Tunis
- [13].HAJ TAIEB Mohammed « suivi de la performance du réseau GSM à partir des messages captés au niveau de l'interface A, SUPCOM Tunis : [fr.scribd.com/doc/38899173/HAJ-TAIEB-Mohamed](http://fr.scribd.com/doc/38899173/HAJ-TAIEB-Mohamed)
- [14].« principe de base du fonctionnement du réseau GSM » : <http://www.ulg.ac.be/telecom/publi/publications/mvd/Demoulin2004Principes>
- [15].« Réseaux mobiles » cours LPRT école ISI année 2011-2012
- [16].« QoS dans les réseaux mobiles » cours LPRT école ISI année 2011-2012.
- [17].Henon J., Bidal C., « UMTS La Télécommunication Universelle », MMA Promo 2001, Août 2001.
- [18].Sanchez J., « UMTS », 2eédition, Mars 2004.
- [19].Atmani A., Bahhar A., El Aoumari T., « Universal Mobile Telecommunications System: architecture, couches et interfaces », ENSEIRIB, 12 Janvier 2005.

## References

---

- [20]. M. K. Rastogi, « Developing a QOS aware Framework for LTE », Aricent Group, 2012.
- [21]. <http://www.techtrained.com> : 22:00:00-21/05/2021.
- [22]. <https://derekcheung.medium.com> : 18:00:00-22/05/2021.
- [23]. <https://www.techplayon.com> : 22:00:00-25/05/2021.
- [24]. <https://derekcheung.medium.com> : 15:00:00-27/05/2021.
- [25]. <https://www.techplayon.com> : 22:00:00-28/05/2021.
- [26]. <https://devopedia.org> : 23:00:00-30/06/2021.

## Abstract

The fifth-generation mobile network that will replace the fourth-generation cellular technology with multiple super data speeds up to 10 gigabits per second, a very low arrival time of less than milliseconds. It also promises to accelerate the development and widespread adoption of many emerging innovations, which are currently limited to smart cities and self-driving vehicles. On the peripheral public awareness, like the Internet of Things in this work, we did a study on the quality of service in the fifth generation, which plays an important role in this technology and which will provide several advantages in terms of speed and low loss of data that were a problem in previous generations. We will use Matlab to simulate one of the techniques that will improve the quality of service and avoid the loss of packages, where we simulated the multi-antenna technology that has proved effective.

### ملخص:

شبكة الجيل الخامس من الهاتف المحمول التي ستحل محل تقنية الجيل الرابع الخلوية بسرعة بيانات فائقة متعددة تصل إلى 10 جيجابت في الثانية، زمن وصول منخفض للغاية أقل من ميلي ثانية. كما يعد بتسريع تطوير العديد من الابتكارات الناشئة واعتمادها على نطاق واسع، وهي تقتصر حالياً، والمدن الذكية، والمركبات ذاتية القيادة. على الوعي العام المحيطي، مثل إنترنت الأشياء في هذا العمل قمنا بدراسة حول جودة الخدمة في الجيل الخامس والتي تلعب دور هام في هذه التقنية والتي ستوفر عدة امتيازات من ناحية السرعة وانخفاض ضياع البيانات التي كانت تشكل مشكلة في الأجيال السابقة. سوف نستخدم برنامج Matlab لمحاكاة أحد التقنيات التي من شأنها أن تحسن جودة الخدمة وتقادي ضياع الحزم حيث قمنا بمحاكاة تقنية تعدد الهوائيات والتي أثبتت فعاليتها.

### Résumé :

Le réseau mobile de cinquième génération qui remplacera la technologie cellulaire de quatrième génération par de multiples super données à des vitesses allant jusqu'à 10 gigabits par seconde, un temps d'arrivée très faible de moins de millisecondes. Il promet également d'accélérer le développement et l'adoption généralisée de nombreuses innovations émergentes, actuellement limitées aux villes intelligentes et aux véhicules autonomes. En ce qui concerne la sensibilisation du public périphérique, comme l'Internet des objets dans ce travail, nous avons fait une étude sur la qualité du service dans la cinquième génération, qui joue un rôle important dans cette technologie et qui fournira plusieurs avantages en termes de vitesse et de faible perte de données qui ont été un problème dans les générations précédentes. Nous utiliserons Matlab pour simuler l'une des techniques qui améliorera la qualité du service et évitera la perte de paquets, où nous avons simulé la technologie multi-antennes qui s'est avérée efficace.